

ZGM130S Z-Wave 700 SiP Module Data Sheet

The Silicon Labs Z-Wave 700 SiP Module, ZGM130S, is a fully integrated Z-Wave module, enabling rapid development of Z-Wave solutions.

It is an ideal solution for energy-friendly smart home control applications such as motion sensors, door/window sensors, access control, appliance control, building automation, energy management, lighting, and security networks in the “Internet of Things”.

Built with low-power Gecko technology, which includes innovative low energy techniques, fast wake-up times and energy saving modes, the ZGM130S reduces overall power consumption and maximizes battery life.

The module contains a native security stack and a comprehensive set of hardware peripherals usable for advanced device functionality, and offers 64 kB of flash memory for OEM applications.

Z-Wave 700 ZGM130S modules can be used in a wide variety of applications:

- Smart Home
- Security
- Lighting
- Health and Wellness
- Metering
- Building Automation

KEY FEATURES

- TX power up to 14 dBm
- RX sensitivity @ 100 kbps: -103.9 dBm
- Range: up to 1 mile
- 9.8 mA RX current at 100 kbps, GFSK, 868 MHz
- 13.3 mA TX current at 0 dBm output power at 908 MHz
- 0.8 μ A EM4H current (128 Byte RAM retention and RTCC running from LFRCO)
- 32-bit ARM[®] Cortex[®]-M4 core at 39 MHz
- Flash memory: 512 kB (64 kB Application)
- RAM: 64 kB (8 kB Application)
- Autonomous Hardware Crypto Accelerator and Random Number Generator
- Integrated DC-DC Converter
- Robust peripheral set and up to 32 GPIO
- External SAW filter optional

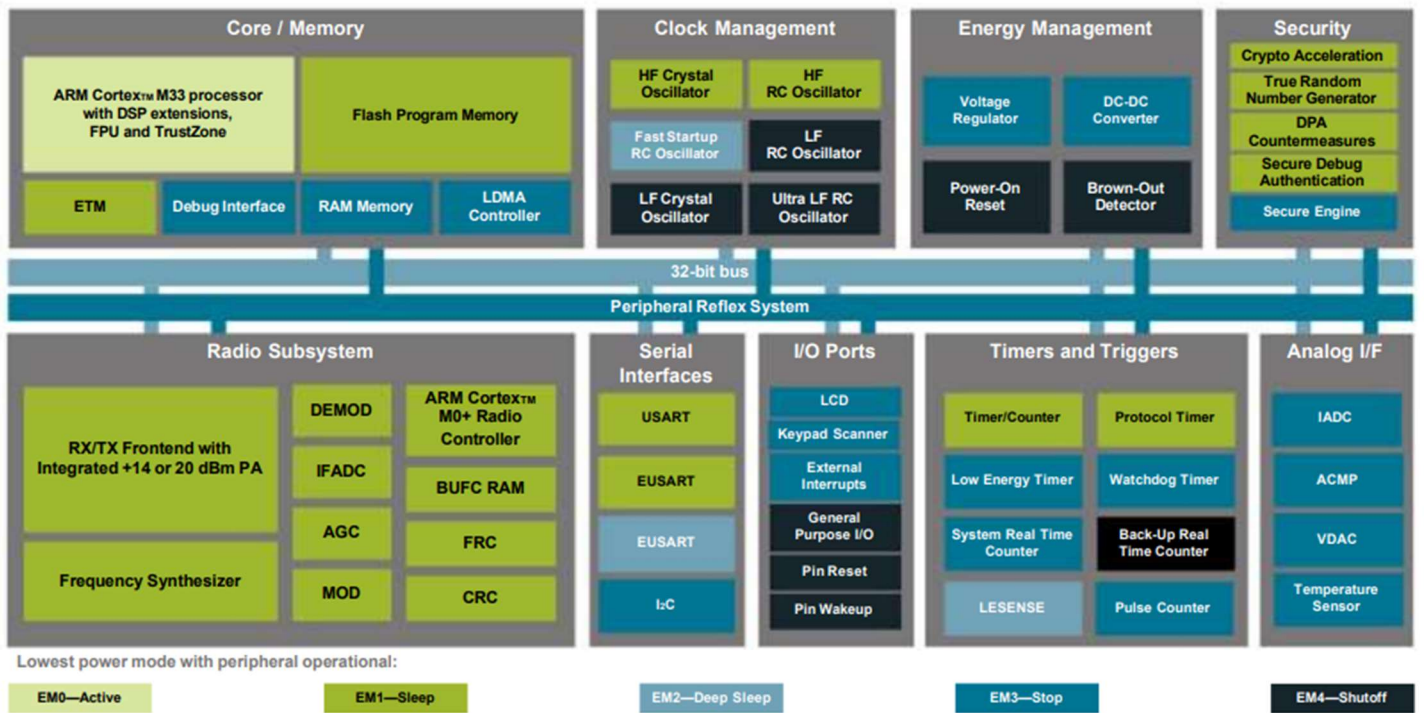

1. Feature List

The ZGM130S highlighted features are listed below.

- **Low Power Wireless System-on-Chip.**
 - High Performance 32-bit, 39 MHz ARM Cortex ®-M4 with DSP instruction and floating-point unit for efficient signal processing
 - Embedded Trace Macrocell (ETM) for advanced debugging
 - 512 kB flash program memory (64 kB available for user applications)
 - 64 kB RAM data memory (8kB available for user applications)
 - TX power up to 14 dBm
 - Supports optional external SAW filter
- **Low Energy Consumption**
 - 9.8 mA RX current at 100 kbps, GFSK, 868 MHz
 - 40.1 mA TX current at 14 dBm output power at 912 MHz
 - 40.7 mA TX current at 13 dBm output power at 868 MHz
 - 13.3 mA TX current at 0 dBm output power at 908 MHz
 - 69 µA/MHz in Active Mode (EM0)
 - 0.8 µA EM4 current (128 Byte RAM retention and RTCC running from LFRCO)
- **High Receiver Performance**
 - -97.9 dBm sensitivity at 100 kbit/s GFSK, 868 MHz
 - -97.5 dBm sensitivity at 100 kbit/s GFSK, 915 MHz
 - -103.9 dBm sensitivity at 100 kbit/s DSSS O-QPSK, 912 MHz
- **Supported Protocols:**
 - Z-Wave
 - Z-Wave Long Range
- **Support for Internet Security**
 - General Purpose CRC
 - True Random Number Generator (TRNG)
 - 2 × Hardware Cryptographic Acceleration for AES 128/256, SHA-1, SHA-2 (SHA-224 and SHA-256) and ECC
- **Wide selection of MCU peripherals**
 - 12-bit 1 Msps SAR Analog to Digital Converter (ADC)
 - 2 × Analog Comparator (ACMP)
 - 2 × Digital to Analog Converter (VDAC)
 - 3 × Operational Amplifier (Opamp)
 - Digital to Analog Current Converter (IDAC)
 - Low-Energy Sensor Interface (LESENSE)
 - Multi-channel Capacitive Sense Interface (CSEN)
 - 32 pins connected to analog channels (APORT) shared between analog peripherals
 - 32 General Purpose I/O pins with output state retention and asynchronous interrupts
 - 8 Channel DMA Controller
 - 12 Channel Peripheral Reflex System (PRS)
 - 2 × 16-bit Timer/Counter
 - 3 or 4 Compare/Capture/PWM channels
 - 1 × 32-bit Timer/Counter
 - 3 Compare/Capture/PWM channels
 - 32-bit Real Time Counter and Calendar
 - 16-bit Low Energy Timer for waveform generation
 - 32-bit Ultra Low Energy Timer/Counter for periodic wake-up from any Energy Mode
 - 16-bit Pulse Counter with asynchronous operation
 - 2 × Watchdog Timer
 - 3 × Universal Synchronous/Asynchronous Receiver/Transmitter (UART/SPI/SmartCard (ISO 7816)/IrDA/I2S)
 - Low Energy UART (LEUART™)
 - 2 × I2c interface with SMBus support and address recognition in EM3 Stop
- **Wide Operating Range**
 - 1.8 V to 3.8 V single power supply
 - Integrated DC-DC
 - -40 °C to 85 °C
- **Dimensions**
 - 9 × 9 × 1.21 mm

2. Ordering Information

Table 2.1. Ordering Information

Ordering Code	Protocol Stack	Max TX Power	Antenna	Flash (kB)	RAM (kB)	GPIO	Carrier
ZGM130S037HGN2	Z-Wave	14 dBm	RF pin	512	64	32	Tray
ZGM130S037HGN2R	Z-Wave	14 dBm	RF pin	512	64	32	Tape & Reel

Table of Contents

1. Feature List	2
2. Ordering Information	3
3. System Overview.	7
3.1 Introduction	7
3.2 Radio	7
3.2.1 Antenna Interface	7
3.2.2 Packet and State Trace	8
3.2.3 Random Number Generator	8
3.3 Power	9
3.3.1 Energy Management Unit (EMU)	9
3.3.2 DC-DC Converter	9
3.3.3 Power Domains	9
3.4 General Purpose Input/Output (GPIO)	9
3.5 Clocking	9
3.5.1 Clock Management Unit (CMU)	9
3.5.2 Internal Oscillators and Crystals.	10
3.6 Counters/Timers and PWM.	10
3.6.1 Timer/Counter (TIMER)	10
3.6.2 Wide Timer/Counter (WTIMER)	10
3.6.3 Real Time Counter and Calendar (RTCC)	10
3.6.4 Low Energy Timer (LETIMER)	10
3.6.5 Ultra Low Power Wake-up Timer (CRYOTIMER)	10
3.6.6 Pulse Counter (PCNT)	11
3.6.7 Watchdog Timer (WDOG).	11
3.7 Communications and Other Digital Peripherals	11
3.7.1 Universal Synchronous/Asynchronous Receiver/Transmitter (USART).	11
3.7.2 Low Energy Universal Asynchronous Receiver/Transmitter (LEUART).	11
3.7.3 Inter-Integrated Circuit Interface (I2C)	11
3.7.4 Peripheral Reflex System (PRS)	11
3.7.5 Low Energy Sensor Interface (LESENSE)	11
3.8 Security Features	11
3.8.1 GPCRC (General Purpose Cyclic Redundancy Check)	11
3.8.2 Crypto Accelerator (CRYPTO)	12
3.8.3 True Random Number Generator (TRNG)	12
3.8.4 Security Management Unit (SMU)	12
3.9 Analog.	12
3.9.1 Analog Port (APORT)	12
3.9.2 Analog Comparator (ACMP)	12
3.9.3 Analog to Digital Converter (ADC)	12
3.9.4 Capacitive Sense (CSEN).	12
3.9.5 Digital to Analog Current Converter (IDAC)	13
3.9.6 Digital to Analog Converter (VDAC)	13

3.9.7 Operational Amplifiers13
3.10 Reset Management Unit (RMU)13
3.11 Core and Memory13
3.11.1 Processor Core13
3.11.2 Memory System Controller (MSC)13
3.11.3 Linked Direct Memory Access Controller (LDMA)13
3.12 Memory Map14
3.13 Configuration Summary15
4. Electrical Specifications16
4.1 Electrical Characteristics16
4.1.1 Absolute Maximum Ratings16
4.1.2 Operating Conditions17
4.1.3 DC-DC Converter18
4.1.4 Current Consumption20
4.1.5 Wake Up Times23
4.1.6 Brown Out Detector (BOD)23
4.1.7 Frequency Synthesizer.24
4.1.8 Sub-GHz RF Transceiver Characteristics25
4.1.9 Oscillators33
4.1.10 Flash Memory Characteristics35
4.1.11 General-Purpose I/O (GPIO)36
4.1.12 Voltage Monitor (VMON).38
4.1.13 Analog to Digital Converter (ADC)39
4.1.14 Analog Comparator (ACMP)41
4.1.15 Digital to Analog Converter (VDAC)43
4.1.16 Current Digital to Analog Converter (IDAC)46
4.1.17 Capacitive Sense (CSEN)48
4.1.18 Operational Amplifier (OPAMP)50
4.1.19 Pulse Counter (PCNT)53
4.1.20 Analog Port (APORT).53
4.1.21 I2C54
4.1.22 USART SPI Master Timing57
4.1.23 USART SPI Slave Timing58
4.2 Typical Performance Curves58
4.2.1 Zwave Radio59
5. Typical Connection Diagrams60
5.1 Typical ZGM130S Connections60
6. Pin Definitions61
6.1 ZGM130S Device Pinout61
6.2 GPIO Functionality Table64
6.3 Alternate Functionality Overview92
6.4 Analog Port (APORT) Client Maps104
7. LGA64 Package Specifications.113

7.1 LGA64 Package Dimensions114

7.2 LGA64 PCB Land Pattern116

7.3 LGA64 Package Marking 117.

8. Certifications118

9. Revision History119

3. System Overview

3.1 Introduction

The ZGM130S product family combines an energy-friendly MCU with a highly integrated radio transceiver. The devices are well suited for any battery operated application, as well as other system where ultra-small size, reliable high performance RF, low-power consumption and easy application development are key requirements. This section gives a short introduction to the full radio and MCU system.

Note: The hardware functions available to application code are strictly affected by the services enabled in the Z-Wave protocol stack and the version of the stack that is used. The software release note (SRN) for the used Z-Wave protocol version should be consulted to determine whether a specific hardware block is made available by the stack through the Z-Wave API for end-application use.

A detailed block diagram of the ZGM130S module is shown in the figure below.

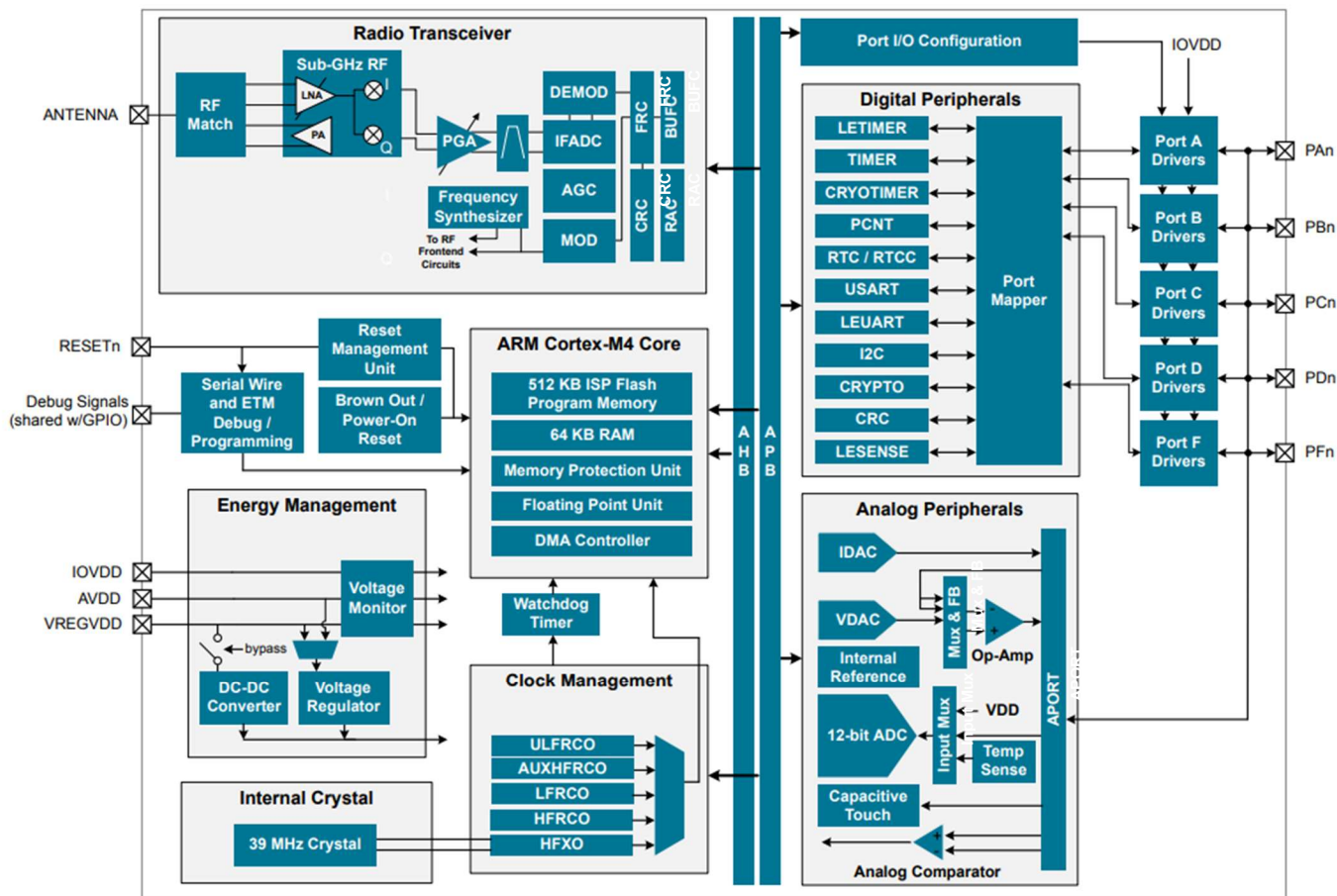

Figure 3.1. ZGM130S Block Diagram

3.2 Radio

The ZGM130S features a radio transceiver supporting Z-Wave protocol.

3.2.1 Antenna Interface

The antenna interface consists of a single pin, connected to internal balun and matching network.

3.2.2 Packet and State Trace

The ZGM130S Frame Controller has a packet and state trace unit that provides valuable information during the development phase. It features:

- Non-intrusive trace of transmit data, receive data and state information
- Data observability on a single-pin UART data output, or on a two-pin SPI data output
- Configurable data output bitrate / baudrate
- Multiplexed transmitted data, received data and state / meta information in a single serial data stream

3.2.3 Random Number Generator

The Frame Controller (FRC) implements a random number generator that uses entropy gathered from noise in the RF receive chain. The data is suitable for use in cryptographic applications.

Output from the random number generator can be used either directly or as a seed or entropy source for software-based random number generator algorithms such as Fortuna.

3.3 Power

The ZGM130S has an Energy Management Unit (EMU) and efficient integrated regulators to generate internal supply voltages. Only a single external supply voltage is required, from which all internal voltages are created. An integrated DC-DC buck regulator is utilized to further reduce the current consumption.

3.3.1 Energy Management Unit (EMU)

The Energy Management Unit manages transitions of energy modes in the device. Each energy mode defines which peripherals and features are available and the amount of current the device consumes. The EMU can also be used to turn off the power to unused RAM blocks, and it contains control registers for the dc-dc regulator and the Voltage Monitor (VMON). The VMON is used to monitor multiple supply voltages. It has multiple channels which can be programmed individually by the user to determine if a sensed supply has fallen below a chosen threshold.

3.3.2 DC-DC Converter

The dc-dc buck converter covers a wide range of load currents and provides up to 90% efficiency in energy modes EM0, EM1, EM2 and EM3. Patented RF noise mitigation allows operation of the dc-dc converter without degrading sensitivity of radio components. Protection features include programmable current limiting, short-circuit protection, and dead-time protection. The dc-dc converter may also enter bypass mode when the input voltage is too low for efficient operation. In bypass mode, the dc-dc input supply is internally connected directly to its output through a low resistance switch. Bypass mode also supports in-rush current limiting to prevent input supply voltage droops due to excessive output current transients.

3.3.3 Power Domains

The ZGM130S has two peripheral power domains for operation in EM2 and EM3. If all of the peripherals in a peripheral power domain are configured as unused, the power domain for that group will be powered off in the low-power mode, reducing the overall current consumption of the device.

Table 3.1. Peripheral Power Subdomains

Peripheral Power Domain 1	Peripheral Power Domain 2
ACMP0	ACMP1
PCNT0	CSEN
ADC0	VDAC0
LETIMER0	LEUART0
LESENSE	I2C0
APOINT	I2C1
-	IDAC

3.4 General Purpose Input/Output (GPIO)

ZGM130S has up to 32 General Purpose Input/Output pins. Each GPIO pin can be individually configured as either an output or input. More advanced configurations including open-drain, open-source, and glitch-filtering can be configured for each individual GPIO pin. The GPIO pins can be overridden by peripheral connections, like SPI communication. Each peripheral connection can be routed to several GPIO pins on the device. The input value of a GPIO pin can be routed through the Peripheral Reflex System to other peripherals. The GPIO subsystem supports asynchronous external pin interrupts.

3.5 Clocking

3.5.1 Clock Management Unit (CMU)

The Clock Management Unit controls oscillators and clocks in the ZGM130S. Individual enabling and disabling of clocks to all peripherals is performed by the CMU. The CMU also controls enabling and configuration of the oscillators. A high degree of flexibility allows software to optimize energy consumption in any specific application by minimizing power dissipation in unused peripherals and oscillators.

3.5.2 Internal Oscillators and Crystals

The ZGM130S fully integrates several oscillator sources and a high frequency crystal.

- The high-frequency crystal oscillator (HFXO) and integrated 39 MHz crystal provide a precise timing reference for the MCU and radio.
- An integrated high frequency RC oscillator (HFRCO) is available for the MCU system, when crystal accuracy is not required. The HFRCO employs fast startup at minimal energy consumption combined with a wide frequency range.
- An integrated auxiliary high frequency RC oscillator (AUXHFRCO) is available for timing the general-purpose ADC and the Serial Wire Viewer port with a wide frequency range.
- An integrated low frequency 32.768 kHz RC oscillator (LFRCO) for low power operation where high accuracy is not required.
- An integrated ultra-low frequency 1 kHz RC oscillator (ULFRCO) is available to provide a timing reference at the lowest energy consumption in low energy modes.

3.6 Counters/Timers and PWM

3.6.1 Timer/Counter (TIMER)

TIMER peripherals keep track of timing, count events, generate PWM outputs and trigger timed actions in other peripherals through the PRS system. The core of each TIMER is a 16-bit counter with up to 4 compare/capture channels. Each channel is configurable in one of three modes. In capture mode, the counter state is stored in a buffer at a selected input event. In compare mode, the channel output reflects the comparison of the counter to a programmed threshold value. In PWM mode, the TIMER supports generation of pulse-width modulation (PWM) outputs of arbitrary waveforms defined by the sequence of values written to the compare registers, with optional dead-time insertion available in timer unit TIMER_0 only.

3.6.2 Wide Timer/Counter (WTIMER)

WTIMER peripherals function just as TIMER peripherals, but are 32 bits wide. They keep track of timing, count events, generate PWM outputs and trigger timed actions in other peripherals through the PRS system. The core of each WTIMER is a 32-bit counter with up to 4 compare/capture channels. Each channel is configurable in one of three modes. In capture mode, the counter state is stored in a buffer at a selected input event. In compare mode, the channel output reflects the comparison of the counter to a programmed threshold value. In PWM mode, the WTIMER supports generation of pulse-width modulation (PWM) outputs of arbitrary waveforms defined by the sequence of values written to the compare registers, with optional dead-time insertion available in timer unit WTIMER_0 only.

3.6.3 Real Time Counter and Calendar (RTCC)

The Real Time Counter and Calendar (RTCC) is a 32-bit counter providing timekeeping in all energy modes. The RTCC includes a Binary Coded Decimal (BCD) calendar mode for easy time and date keeping. The RTCC can be clocked by any of the on-board oscillators with the exception of the AUXHFRCO, and it is capable of providing system wake-up at user defined instances. When receiving frames, the RTCC value can be used for timestamping. The RTCC includes 128 bytes of general purpose data retention, allowing easy and convenient data storage in all energy modes down to EM4H.

A secondary RTC is used by the RF protocol stack for event scheduling, leaving the primary RTCC block available exclusively for application software.

3.6.4 Low Energy Timer (LETIMER)

The unique LETIMER is a 16-bit timer that is available in energy mode EM0 Active, EM1 Sleep, EM2 Deep Sleep, and EM3 Stop. This allows it to be used for timing and output generation when most of the device is powered down, allowing simple tasks to be performed while the power consumption of the system is kept at an absolute minimum. The LETIMER can be used to output a variety of waveforms with minimal software intervention. The LETIMER is connected to the Real Time Counter and Calendar (RTCC), and can be configured to start counting on compare matches from the RTCC.

3.6.5 Ultra Low Power Wake-up Timer (CRYOTIMER)

The CRYOTIMER is a 32-bit counter that is capable of running in all energy modes. It can be clocked by either the 32.768 kHz RC oscillator (LFRCO) or the 1 kHz RC oscillator (ULFRCO). It can provide periodic Wakeup events and PRS signals which can be used to wake up peripherals from any energy mode. The CRYOTIMER provides a wide range of interrupt periods, facilitating flexible ultra-low energy operation.

3.6.6 Pulse Counter (PCNT)

The Pulse Counter (PCNT) peripheral can be used for counting pulses on a single input or to decode quadrature encoded inputs. The clock for PCNT is selectable from either an external source on pin PCTNn_S0IN or from an internal timing reference, selectable from among any of the internal oscillators, except the AUXHFRCO. The peripheral may operate in energy mode EM0 Active, EM1 Sleep, EM2 Deep Sleep, and EM3 Stop.

3.6.7 Watchdog Timer (WDOG)

The watchdog timer can act both as an independent watchdog or as a watchdog synchronous with the CPU clock. It has windowed monitoring capabilities, and can generate a reset or different interrupts depending on the failure mode of the system. The watchdog can also monitor autonomous systems driven by PRS.

3.7 Communications and Other Digital Peripherals

3.7.1 Universal Synchronous/Asynchronous Receiver/Transmitter (USART)

The Universal Synchronous/Asynchronous Receiver/Transmitter is a flexible serial I/O interface. It supports full duplex asynchronous UART communication with hardware flow control as well as RS-485, SPI, MicroWire and 3-wire. It can also interface with devices supporting:

- ISO7816 SmartCards
- IrDA
- I2S

3.7.2 Low Energy Universal Asynchronous Receiver/Transmitter (LEUART)

The unique LEUART™ provides two-way UART communication on a strict power budget. Only a 32.768 kHz clock is needed to allow UART communication up to 9600 baud. The LEUART includes all necessary hardware to make asynchronous serial communication possible with a minimum of software intervention and energy consumption.

3.7.3 Inter-Integrated Circuit Interface (I2C)

The I2C interface enables communication between the MCU and a serial I2C bus. It is capable of acting as both a master and a slave and supports multi-master buses. Standard-mode, fast-mode and fast-mode plus speeds are supported, allowing transmission rates from 10 kbit/s up to 1 Mbit/s. Slave arbitration and timeouts are also available, allowing implementation of an SMBus-compliant system. The interface provided to software by the I2C peripheral allows precise timing control of the transmission process and highly automated transfers. Automatic recognition of slave addresses is provided in active and low energy modes.

3.7.4 Peripheral Reflex System (PRS)

The Peripheral Reflex System provides a communication network between different peripherals without software involvement. Peripherals producing Reflex signals are called producers. The PRS routes Reflex signals from producers to consumer peripherals, which in turn perform actions in response. Edge triggers and other functionality such as simple logic operations (AND, OR, NOT) can be applied by the PRS to the signals. The PRS allows peripheral to act autonomously without waking the MCU core, saving power.

3.7.5 Low Energy Sensor Interface (LESENSE)

The Low Energy Sensor Interface LESENSE™ is a highly configurable sensor interface with support for up to 16 individually configurable sensors. By controlling the analog comparators, ADC, and DAC, LESENSE is capable of supporting a wide range of sensors and measurement schemes, and can for instance measure LC sensors, resistive sensors and capacitive sensors. LESENSE also includes a programmable finite state machine which enables simple processing of measurement results without CPU intervention. LESENSE is available in energy mode EM2, in addition to EM0 and EM1, making it ideal for sensor monitoring in applications with a strict energy budget.

3.8 Security Features

3.8.1 GPCRC (General Purpose Cyclic Redundancy Check)

The GPCRC block implements a Cyclic Redundancy Check (CRC) function supporting a fully-programmable 16-bit polynomial.

3.8.2 Crypto Accelerator (CRYPTO)

The Crypto Accelerator is a fast and energy-efficient autonomous hardware encryption and decryption accelerator. EFR32 devices support AES encryption and decryption with 128- or 256-bit keys, ECC over both GF(P) and GF(2^m), SHA-1 and SHA-2 (SHA-224 and SHA-256).

Supported block cipher modes of operation for AES include: ECB, CTR, CBC, PCBC, CFB, OFB, GCM, CBC-MAC, GMAC and CCM.

Supported ECC NIST recommended curves include P-192, P-224, P-256, K-163, K-233, B-163 and B-233.

The CRYPTO1 block is tightly linked to the Radio Buffer Controller (BUFC) enabling fast and efficient autonomous cipher operations on data buffer content. It allows fast processing of GCM (AES), ECC and SHA with little CPU intervention.

CRYPTO also provides trigger signals for DMA read and write operations.

3.8.3 True Random Number Generator (TRNG)

The TRNG is a non-deterministic random number generator based on a full hardware solution. The TRNG is validated with NIST800-22 and AIS-31 test suites as well as being suitable for FIPS 140-2 certification (for the purposes of cryptographic key generation).

3.8.4 Security Management Unit (SMU)

The Security Management Unit (SMU) allows software to set up fine-grained security for peripheral access, which is not possible in the Memory Protection Unit (MPU). Peripherals may be secured by hardware on an individual basis, such that only privileged accesses to the peripheral's register interface will be allowed. When an access fault occurs, the SMU reports the specific peripheral involved and can optionally generate an interrupt.

3.9 Analog

3.9.1 Analog Port (APORT)

The Analog Port (APORT) is an analog interconnect matrix allowing access to many analog peripherals on a flexible selection of pins. Each APORT bus consists of analog switches connected to a common wire. Since many clients can operate differentially, buses are grouped by X/Y pairs.

3.9.2 Analog Comparator (ACMP)

The Analog Comparator is used to compare the voltage of two analog inputs, with a digital output indicating which input voltage is higher. Inputs are selected from among internal references and external pins. The tradeoff between response time and current consumption is configurable by software. Two 6-bit reference dividers allow for a wide range of internally-programmable reference sources. The ACMP can also be used to monitor the supply voltage. An interrupt can be generated when the supply falls below or rises above the programmable threshold.

3.9.3 Analog to Digital Converter (ADC)

The ADC is a Successive Approximation Register (SAR) architecture, with a resolution of up to 12 bits at up to 1 Msps. The output sample resolution is configurable and additional resolution is possible using integrated hardware for averaging over multiple samples. The ADC includes integrated voltage references and an integrated temperature sensor. Inputs are selectable from a wide range of sources, including pins configurable as either single-ended or differential.

3.9.4 Capacitive Sense (CSEN)

The CSEN peripheral is a dedicated Capacitive Sensing block for implementing touch-sensitive user interface elements such as switches and sliders. The CSEN peripheral uses a charge ramping measurement technique, which provides robust sensing even in adverse conditions including radiated noise and moisture. The peripheral can be configured to take measurements on a single port pin or scan through multiple pins and store results to memory through DMA. Several channels can also be shorted together to measure the combined capacitance or implement wake-on-touch from very low energy modes. Hardware includes a digital accumulator and an averaging filter, as well as digital threshold comparators to reduce software overhead.

3.9.5 Digital to Analog Current Converter (IDAC)

The IDAC can source or sink a configurable constant current. This current can be driven on an output pin or routed to the selected ADC input pin for capacitive sensing. The full-scale current is programmable between 0.05 μA and 64 μA with several ranges consisting of various step sizes.

3.9.6 Digital to Analog Converter (VDAC)

The Digital to Analog Converter (VDAC) can convert a digital value to an analog output voltage. The VDAC is a fully differential, 500 ksp/s, 12-bit converter. The opamps are used in conjunction with the VDAC, to provide output buffering. One opamp is used per single-ended channel, or two opamps are used to provide differential outputs. The VDAC may be used for a number of different applications such as sensor interfaces or sound output. The VDAC can generate high-resolution analog signals while the MCU is operating at low frequencies and with low total power consumption. Using DMA and a timer, the VDAC can be used to generate waveforms without any CPU intervention. The VDAC is available in all energy modes down to and including EM3.

3.9.7 Operational Amplifiers

The opamps are low power amplifiers with a high degree of flexibility targeting a wide variety of standard opamp application areas, and are available down to EM3. With flexible built-in programming for gain and interconnection they can be configured to support multiple common opamp functions. All pins are also available externally for filter configurations. Each opamp has a rail to rail input and a rail to rail output. They can be used in conjunction with the VDAC peripheral or in stand-alone configurations. The opamps save energy, PCB space, and cost as compared with standalone opamps because they are integrated on-chip.

3.10 Reset Management Unit (RMU)

The RMU is responsible for handling reset of the ZGM130S. A wide range of reset sources are available, including several power supply monitors, pin reset, software controlled reset, core lockup reset, and watchdog reset.

3.11 Core and Memory

3.11.1 Processor Core

The ARM Cortex-M processor includes a 32-bit RISC processor integrating the following features and tasks in the system:

- ARM Cortex-M4 RISC processor achieving 1.25 Dhrystone MIPS/MHz
- Memory Protection Unit (MPU) supporting up to 8 memory segments
- Up to 512 kB flash program memory
- Up to 64 kB RAM data memory
- Configuration and event handling of all peripherals
- 2-pin Serial-Wire debug interface

3.11.2 Memory System Controller (MSC)

The Memory System Controller (MSC) is the program memory unit of the microcontroller. The flash memory is readable and writable from both the Cortex-M and DMA. The flash memory is divided into two blocks; the main block and the information block. Program code is normally written to the main block, whereas the information block is available for special user data and flash lock bits. There is also a read-only page in the information block containing system and device calibration data. Read and write operations are supported in energy modes EM0 Active and EM1 Sleep.

3.11.3 Linked Direct Memory Access Controller (LDMA)

The Linked Direct Memory Access (LDMA) controller allows the system to perform memory operations independently of software. This reduces both energy consumption and software workload. The LDMA allows operations to be linked together and staged, enabling sophisticated operations to be implemented.

3.12 Memory Map

The ZGM130S memory map is shown in the figures below. Note that 64 kB of flash in code space is available for user code. The remainder of the code flash area is reserved for the software stack.

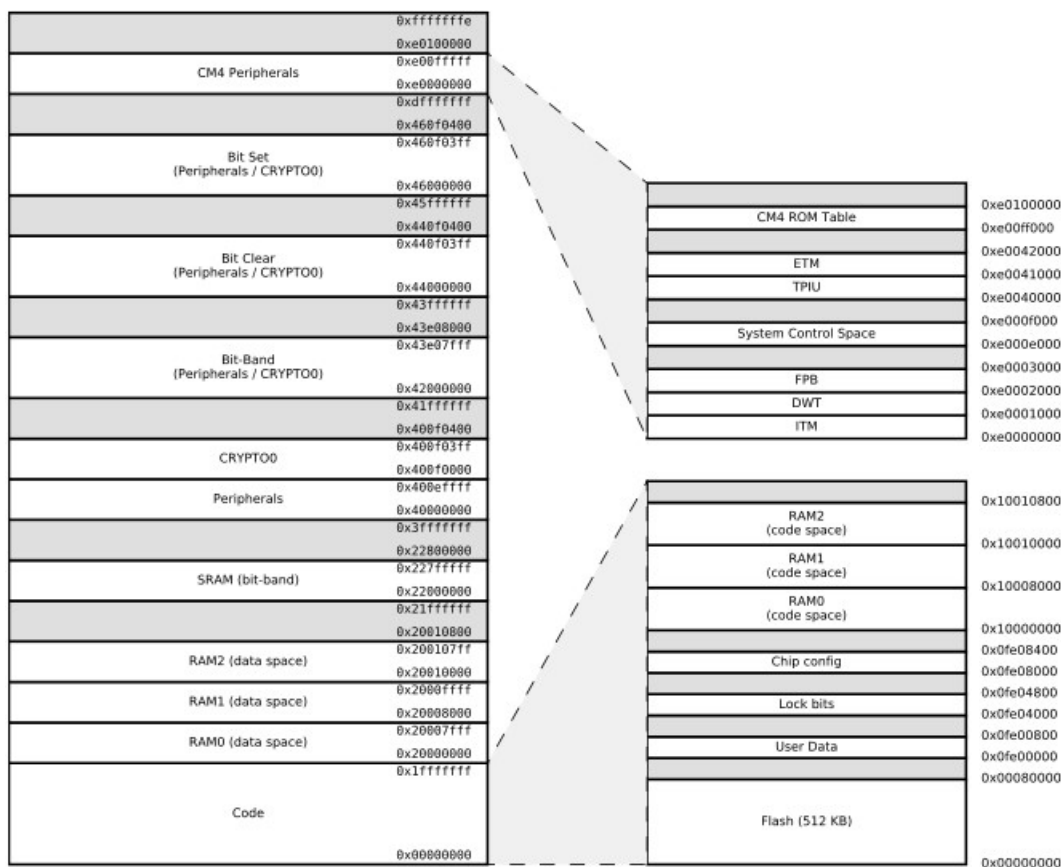

Figure 3.2. ZGM130S Memory Map — Core Peripherals and Code Space

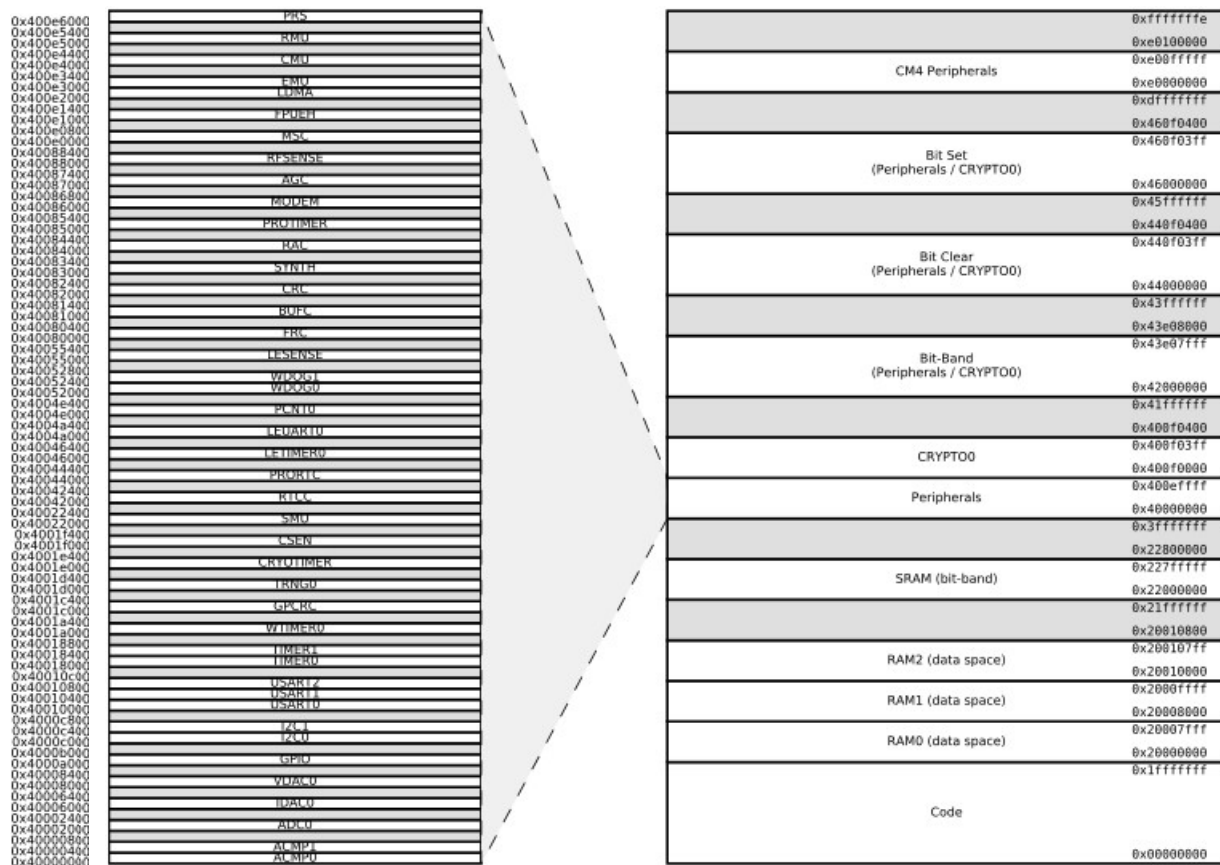

Figure 3.3. ZGM130S Memory Map — Peripherals

3.13 Configuration Summary

The features of the ZGM130S are a subset of the feature set described in the device reference manual. The table below describes device specific implementation of the features. Remaining peripherals support full configuration.

Table 3.2. Configuration Summary

Peripheral	Configuration	Pin Connections
USART0	IrDA SmartCard	US0_TX, US0_RX, US0_CLK, US0_CS
USART1	I2S SmartCard	US1_TX, US1_RX, US1_CLK, US1_CS
USART2	IrDA SmartCard	US2_TX, US2_RX, US2_CLK, US2_CS
TIMER0	with DTI	TIM0_CC[2:0], TIM0_CDTI[2:0]
TIMER1	-	TIM1_CC[3:0]
WTIMER0	with DTI	WTIM0_CC[2:0], WTIM0_CDTI[2:0]

4. Electrical Specifications

4.1 Electrical Characteristics

All electrical parameters in all tables are specified under the following conditions, unless stated otherwise:

- Typical values are based on $T_{AMB}=25\text{ }^{\circ}\text{C}$ and $V_{DD}=3.3\text{ V}$, by production test and/or technology characterization.
- Radio performance numbers are measured in conducted mode, based on Silicon Laboratories reference designs using output power-specific external RF impedance-matching networks for interfacing to a $50\ \Omega$ antenna.
- Minimum and maximum values represent the worst conditions across supply voltage, process variation, and operating temperature, unless stated otherwise.

Refer to for more details about operational supply and temperature limits.

4.1.1 Absolute Maximum Ratings

Stresses above those listed below may cause permanent damage to the device. This is a stress rating only and functional operation of the devices at those or any other conditions above those indicated in the operation listings of this specification is not implied. Exposure to maximum rating conditions for extended periods may affect device reliability. For more information on the available quality and reliability data, see the Quality and Reliability Monitor Report at <http://www.silabs.com/support/quality/pages/default.aspx>.

Table 4.1. Absolute Maximum Ratings

Parameter	Symbol	Test Condition	Min	Typ	Max	Unit
Storage temperature range	TSTG		-40	—	85	$^{\circ}\text{C}$
Voltage on any supply pin	VDDMAX		-0.3	—	3.8	V
Voltage ramp rate on any supply pin	VDDRAMPMAX		—	—	1	V / μs
DC voltage on any GPIO pin	VDIGPIN	5V tolerant GPIO pins ^{1 2 3}	-0.3	—	Min of 5.25 and IOVDD +2	V
		Standard GPIO pins	-0.3	—	IOVDD+0.3	V
Total current into supply pins	IVDDMAX	Source	—	—	200	mA
Total current into VSS ground lines	IVSSMAX	Sink	—	—	200	mA
Current per I/O pin	IIOMAX	Sink	—	—	50	mA
		Source	—	—	50	mA
Current for all I/O pins	IIOALLMAX	Sink	—	—	200	mA
		Source	—	—	200	mA
Junction temperature	TJ		-40	—	105	$^{\circ}\text{C}$

Note:

1. When a GPIO pin is routed to the analog block through the APORT, the maximum voltage = IOVDD.
2. Valid for IOVDD in valid operating range or when IOVDD is undriven (high-Z). If IOVDD is connected to a low-impedance source below the valid operating range (e.g. IOVDD shorted to VSS), the pin voltage maximum is IOVDD + 0.3 V, to avoid exceeding the maximum IO current specifications.
3. To operate above the IOVDD supply rail, over-voltage tolerance must be enabled according to the GPIO_Px_OVTDIS register. Pins with over-voltage tolerance disabled have the same limits as Standard GPIO.

4.1.2 Operating Conditions

When assigning supply sources, the following requirements must be observed:

- VREGVDD = AVDD
- IOVDD ≤ AVDD

4.1.2.1 General Operating Conditions

Table 4.2. General Operating Conditions

Parameter	Symbol	Test Condition	Min	Typ	Max	Unit
Operating ambient temperature range	TA	-G temperature grade	-40	25	85	°C
AVDD supply voltage ¹	VAVDD		1.8	3.3	3.8	V
VREGVDD operating supply voltage ^{1 2}	VVREGVDD	DCDC in regulation	2.4	3.3	3.8	V
		DCDC in bypass, 50mA load	1.8	3.3	3.8	V
VREGVDD current	IVREGVDD	DCDC in bypass, T ≤ 85 °C	—	—	200	mA
IOVDD operating supply voltage	VIOVDD	All IOVDD pins ³	1.62	—	VVREGVDD	V
HFCORECLK frequency	fCORE	VSCALE2, MODE = WS1	—	—	39	MHz
HFCLK frequency	fHFCLK	VSCALE2	—	—	39	MHz

Note:

- 1.VREGVDD must be tied to AVDD. Both VREGVDD and AVDD minimum voltages must be satisfied for the part to operate.
- 2.The minimum voltage required in bypass mode is calculated using RBYP from the DCDC specification table. Requirements for other loads can be calculated as $V_{DVDD_min} + I_{LOAD} * R_{BYP_max}$.
- 3.When the CSEN peripheral is used with chopping enabled (CSEN_CTRL_CHOPEN = ENABLE), IOVDD must be equal to AVDD.

4.1.3 DC-DC Converter

Test conditions: V_DCDC_I=3.3 V, V_DCDC_O=1.8 V, I_DCDC_LOAD=50 mA, Heavy Drive configuration, F_DCDC_LN=7 MHz, unless otherwise indicated.

Table 4.3. DC-DC Converter

Parameter	Symbol	Test Condition	Min	Typ	Max	Unit
Input voltage range	VDCDC_I	Bypass mode, IDCDC_LOAD = 50 mA	1.8	—	VVREGVDD_MAX	V
		Low noise (LN) mode, 1.8 V output, IDCDC_LOAD = 100 mA, or Low power (LP) mode, 1.8 V output, IDCDC_LOAD = 10 mA	2.4	—	VVREGVDD_MAX	V
Output voltage programmable range ¹	VDCDC_O		1.8	—	VVREGVDD	V
Regulation DC accuracy	ACCDC	Low Noise (LN) mode, 1.8 V target output	1.7	—	1.9	V
Regulation window ²	WINREG	Low Power (LP) mode, LPCMPBIASEMxx3 = 0, 1.8 V target output, IDCDC_LOAD ≤ 75 μA	1.63	—	2.2	V
		Low Power (LP) mode, LPCMPBIASEMxx3 = 3, 1.8 V target output, IDCDC_LOAD ≤ 10 mA	1.63	—	2.1	V
Steady-state output ripple	VR	Radio disabled	—	3	—	mVpp
Output voltage under/overshoot	Vov	CCM Mode (LNFORCECCM3 = 1), Load changes between 0 mA and 100 mA	—	25	60	mV
		DCM Mode (LNFORCECCM3 = 0), Load changes between 0 mA and 10 mA	—	45	90	mV
		Overshoot during LP to LN CCM/DCM mode transitions compared to DC level in LN mode	—	200	—	mV
		Undershoot during BYP/LP to LN CCM (LNFORCECCM3 = 1) mode transitions compared to DC level in LN mode	—	40	—	mV
		Undershoot during BYP/LP to LN DCM (LNFORCECCM3 = 0) mode transitions compared to DC level in LN mode	—	100	—	mV
DC line regulation	VREG	Input changes between VVREGVDD_MAX and 2.4 V	—	0.1	—	%
DC load regulation	IREG	Load changes between 0 mA and 100 mA in CCM mode	—	0.1	—	%

Parameter	Symbol	Test Condition	Min	Typ	Max	Unit
Max load current	ILOAD_MAX	Low noise (LN) mode, Medium or Heavy Drive ⁴	—	—	80	mA
		Low noise (LN) mode, Light Drive ⁴	—	—	50	mA
		Low power (LP) mode, LPCMPBIASEM _{xx3} = 0	—	—	75	μA
		Low power (LP) mode, LPCMPBIASEM _{xx3} = 3	—	—	10	mA

Note:

1. Due to internal dropout, the DC-DC output will never be able to reach its input voltage, VVREGVDD.
2. LP mode controller is a hysteretic controller that maintains the output voltage within the specified limits.
3. LPCMPBIASEM_{xx} refers to either LPCMPBIASEM234H in the EMU_DCDCMISCCTRL register or LPCMPBIASEM01 in the EMU_DCDCLOEM01CFG register, depending on the energy mode.
4. Drive levels are defined by configuration of the PFETCNT and NFETCNT registers. Light Drive: PFETCNT=NFETCNT=3; Medium Drive: PFETCNT=NFETCNT=7; Heavy Drive: PFETCNT=NFETCNT=15.

4.1.4 Current Consumption

4.1.4.1 Current Consumption 3.3 V using DC-DC Converter

Unless otherwise indicated, typical conditions are: VREGVDD = AVDD = IOVDD = 3.3 V, 1V8 = 1.8 V DC-DC output. T = 25 °C. Minimum and maximum values in this table represent the worst conditions across process variation at T = 25 °C.

Table 4.4. Current Consumption 3.3 V using DC-DC Converter

Parameter	Symbol	Test Condition	Min	Typ	Max	Unit
Current consumption in EM0 mode with all peripherals disabled, DCDC in Low Noise DCM mode ¹	IACTIVE_DCM	39 MHz crystal, CPU running while loop from flash ²	—	87	—	µA/MHz
		38 MHz HFRCO, CPU running Prime from flash	—	69	—	µA/MHz
		38 MHz HFRCO, CPU running while loop from flash	—	70	—	µA/MHz
		38 MHz HFRCO, CPU running CoreMark from flash	—	82	—	µA/MHz
		26 MHz HFRCO, CPU running while loop from flash	—	76	—	µA/MHz
		1 MHz HFRCO, CPU running while loop from flash	—	615	—	µA/MHz
Current consumption in EM0 mode with all peripherals disabled, DCDC in Low Noise CCM mode ³	IACTIVE_CCM	39 MHz crystal, CPU running while loop from flash ²	—	97	—	µA/MHz
		38 MHz HFRCO, CPU running Prime from flash	—	80	—	µA/MHz
		38 MHz HFRCO, CPU running while loop from flash	—	81	—	µA/MHz
		38 MHz HFRCO, CPU running CoreMark from flash	—	92	—	µA/MHz
		26 MHz HFRCO, CPU running while loop from flash	—	94	—	µA/MHz
		1 MHz HFRCO, CPU running while loop from flash	—	1145	—	µA/MHz
Current consumption in EM0 mode with all peripherals disabled and voltage scaling enabled, DCDC in Low Noise CCM mode ³	IACTIVE_CCM_VS	19 MHz HFRCO, CPU running while loop from flash	—	101	—	µA/MHz
		1 MHz HFRCO, CPU running while loop from flash	—	1124	—	µA/MHz
Current consumption in EM1 mode with all peripherals disabled, DCDC in Low Noise DCM mode ¹	IEM1_DCM	39 MHz crystal ²	—	56	—	µA/MHz
		38 MHz HFRCO	—	39	—	µA/MHz
		26 MHz HFRCO	—	46	—	µA/MHz
		1 MHz HFRCO	—	588	—	µA/MHz
Current consumption in EM1 mode with all peripherals disabled and voltage scaling enabled, DCDC in Low Noise DCM mode ¹	IEM1_DCM_VS	19 MHz HFRCO	—	50	—	µA/MHz
		1 MHz HFRCO	—	572	—	µA/MHz

Parameter	Symbol	Test Condition	Min	Typ	Max	Unit
Current consumption in EM2 mode, with voltage scaling enabled, DCDC in LP mode ⁴	IEM2_VS	Full 64 kB RAM retention and RTCC running from LFRCO	—	1.5	—	μA
		1 bank RAM retention and RTCC running from LFRCO ⁵	—	1.3	—	μA
Current consumption in EM3 mode, with voltage scaling enabled	IEM3_VS	Full 64 kB RAM retention and CRYOTIMER running from ULFR-CO	—	1.14	—	μA
Current consumption in EM4H mode, with voltage scaling enabled	IEM4H_VS	128 byte RAM retention, RTCC running from LFRCO	—	0.8	—	μA

Note:

- 1.DCDC Low Noise DCM Mode = Light Drive (PFETCNT=NFETCNT=3), F=3.0 MHz (RCOBAND=0), ANASW=DVDD.
- 2.CMU_HFXOCTRL_LOWPOWER=0.
- 3.DCDC Low Noise CCM Mode = Light Drive (PFETCNT=NFETCNT=3), F=6.4 MHz (RCOBAND=4), ANASW=DVDD.
- 4.DCDC Low Power Mode = Medium Drive, LPOSCDIV=1, LPCMPBIASEM234H=0, LPCLIMILIMSEL=1, ANASW=DVDD.
- 5.CMU_LFRCOCTRL_ENVREF = 1, CMU_LFRCOCTRL_VREFUPDATE = 1

4.1.4.2 Current Consumption Using Radio 3.3 V with DC-DC

Unless otherwise indicated, typical conditions are: VREGVDD = AVDD = IOVDD = 3.3 V. DC-DC on. T = 25 °C. Minimum and maximum values in this table represent the worst conditions across process variation at T = 25 °C.

Table 4.5. Current Consumption Using Radio 3.3 V with DC-DC

Parameter	Symbol	Test Condition	Min	Typ	Max	Unit
Current consumption in receive mode, active packet reception (MCU in EM1 @ 39 MHz, peripheral clocks disabled)	IRX_ACTIVE	40 kbit/s, 2FSK, F=868.4 MHz	—	9.6	10	mA
		9.6 kbit/s, Manchester, 2FSK, F=868.42 MHz	—	9.6	10	mA
		100 kbit/s, 2GFSK, F=916.0 MHz	—	9.9	10.3	mA
		40 kbit/s, 2FSK, F=908.4 MHz	—	9.7	10.1	mA
		9.6 kbit/s, Manchester, 2FSK, F=908.42 MHz	—	9.5	9.9	mA
		100 kbit/s, 2GFSK, F=869.85 MHz	—	9.8	10.3	mA
		100 kbit/s, O-QPSK, F=912 MHz	—	10.9	—	mA
Current consumption in receive mode, listening for packet (MCU in EM1 @ 39 MHz, peripheral clocks disabled)	IRX_LISTEN	100 kbit/s, 2GFSK, F=869.85 MHz	—	9.9	10.3	mA
		40 kbit/s, 2FSK, F=868.4 MHz	—	9.7	10.1	mA
		9.6 kbit/s, Manchester, 2FSK, F=868.42 MHz	—	9.6	10	mA
		100 kbit/s, 2GFSK, F=916.0 MHz	—	9.9	10.4	mA
		40 kbit/s, 2FSK, F=908.40 MHz	—	9.7	10.1	mA
		9.6 kbit/s, Manchester, 2FSK, F=908.42 MHz	—	9.5	9.9	mA
		100 kbit/s, O-QPSK, F=912 MHz	—	10.9	—	mA
Current consumption in transmit mode (MCU in EM1 @ 39 MHz, peripheral clocks disabled)	ITX	F=868.4 MHz, CW, 13 dBm output power	—	40.7	—	mA
		F=908.4 MHz, CW, 4 dBm output power	—	17.9	—	mA
		F=908.4 MHz, CW, 0 dBm output power	—	13.3	—	mA
		F=912 MHz, CW, 14 dBm output power	—	40.1	—	mA

4.1.5 Wake Up Times

Table 4.6. Wake Up Times

Parameter	Symbol	Test Condition	Min	Typ	Max	Unit
Wake up time from EM1	tEM1_WU		—	3	—	AHB Clocks
Wake up from EM2	tEM2_WU	Code execution from flash	—	10.9	—	µs
		Code execution from RAM	—	3.8	—	µs
Wake up from EM3	tEM3_WU	Code execution from flash	—	10.9	—	µs
		Code execution from RAM	—	3.8	—	µs
Wake up from EM4H1	tEM4H_WU	Executing from flash	—	90	—	µs
Wake up from EM4S1	tEM4S_WU	Executing from flash	—	300	—	µs
Time from release of reset source to first instruction execution	tRESET	Soft Pin Reset released	—	51	—	µs
		Any other reset released	—	358	—	µs
Power mode scaling time	tSCALE	VSCALE0 to VSCALE2, HFCLK = 19 MHz ^{2 3}	—	31.8	—	µs
		VSCALE2 to VSCALE0, HFCLK = 19 MHz ⁴	—	4.3	—	µs

Note:

1. Time from wake up request until first instruction is executed. Wakeup results in device reset.
2. Scaling up from VSCALE0 to VSCALE2 requires approximately 30.3 µs + 28 HFCLKs.
3. VSCALE0 to VSCALE2 voltage change transitions occur at a rate of 10 mV/µs for approximately 20 µs. During this transition, peak currents will be dependent on the value of the DECOUPLE output capacitor, from 35 mA (with a 1 µF capacitor) to 70 mA (with a 2.7 µF capacitor).
4. Scaling down from VSCALE2 to VSCALE0 requires approximately 2.8 µs + 29 HFCLKs.

4.1.6 Brown Out Detector (BOD)

Table 4.7. Brown Out Detector (BOD)

Parameter	Symbol	Test Condition	Min	Typ	Max	Unit
AVDD BOD threshold	VAVDDBOD	AVDD rising	—	—	1.8	V
		AVDD falling (EM0/EM1)	1.62	—	—	V
		AVDD falling (EM2/EM3)	1.53	—	—	V
AVDD BOD hysteresis	VAVDDBOD_HYST		—	20	—	mV
AVDD BOD response time	tAVDDBOD_DELAY	Supply drops at 0.1V/µs rate	—	2.4	—	µs
EM4 BOD threshold	VEM4DBOD	AVDD rising	—	—	1.7	V
		AVDD falling	1.45	—	—	V
EM4 BOD hysteresis	VEM4BOD_HYST		—	25	—	mV
EM4 BOD response time	tEM4BOD_DELAY	Supply drops at 0.1V/µs rate	—	300	—	µs

4.1.7 Frequency Synthesizer

Table 4.8. Frequency Synthesizer

Parameter	Symbol	Test Condition	Min	Typ	Max	Unit
RF synthesizer frequency range	fRANGE	779 - 956 MHz	779	—	956	MHz
LO tuning frequency resolution with 39 MHz crystal	fRES	779 - 956 MHz	—	—	24	Hz
Frequency deviation resolution with 39 MHz crystal	dfRES	779 - 956 MHz	—	—	24	Hz
Maximum frequency deviation with 39 MHz crystal	dfMAX	779 - 956 MHz	—	—	559	kHz

4.1.8 Sub-GHz RF Transceiver Characteristics

4.1.8.1 Sub-GHz RF Transmitter characteristics for 915 MHz Band

Unless otherwise indicated, typical conditions are: T = 25 °C, VREGVDD = AVDD = IOVDD = 3.3 V. Crystal frequency = 39 MHz. RF frequency band 915 MHz.

Table 4.9. Sub-GHz RF Transmitter characteristics for 915 MHz Band

Parameter	Symbol	Test Condition	Min	Typ	Max	Unit
RF tuning frequency range	FRANGE		902	—	930	MHz
Maximum TX Power ¹	POUTMAX	4 dBm output power setting	—	4	—	dBm
Minimum active TX Power	POUTMIN		—	-30	—	dBm
Output power step size	POUTSTEP	output power > 0 dBm	—	0.5	—	dB
Output power variation vs supply at POUTMAX	POUTVAR_V	1.8 V < VVREGVDD < 3.3 V, T = 25 °C	—	2.72	—	dB
Output power variation vs temperature, peak to peak	POUTVAR_T	-40 to +85 °C	—	1.79	—	dB
Output power variation vs RF frequency	POUTVAR_F	T = 25 °C, Over specified RF tuning frequency range	—	1.11	—	dB
Spurious emissions of harmonics at 3 dBm output power, Conducted measurement, 3dBm match, Test Frequency = 908.4 MHz	SPURHARM_FCC_4	In restricted bands, per FCC Part 15.205 / 15.209	—	-49	-42	dBm
		In non-restricted bands, per FCC Part 15.249	—	-53	-20	dBc
Spurious emissions out-of-band at 3 dBm output power, Conducted measurement, 3dBm match, Test Frequency = 908.4 MHz	SPURROOB_FCC_4	In non-restricted bands, per FCC Part 15.249	—	-70	-20	dBc
		In restricted bands (30-88 MHz), per FCC Part 15.205 / 15.209	—	-58	-46	dBm
		In restricted bands (88-216 MHz), per FCC Part 15.205 / 15.209	—	-70	-56	dBm
		In restricted bands (216-960 MHz), per FCC Part 15.205 / 15.209	—	-70	-52	dBm
		In restricted bands (>960 MHz), per FCC Part 15.205 / 15.209	—	-66	-42	dBm
Power spectral density limit	PSD4	PSD per FCC Part 15.249, 9.6Kbps	—	-0.7	—	dBm/3kHz
		PSD per FCC Part 15.249, 40Kbps	—	2.3	—	dBm/3kHz
		PSD per FCC Part 15.249, 100Kbps	—	-4.1	—	dBm/3kHz

Note:

1.If a SAW filter is used, the output power is 2 - 3 dBm lower due to insertion loss. Always adjust the output power to match the limits set by the RF regulatory authorities for the region in which the device is used.

4.1.8.2 Sub-GHz RF Transmitter characteristics for 915 MHz Band, +14 dBm

This table is for the O-QPSK PHY only at +14 dBm. Unless otherwise indicated, typical conditions are: T = 25 °C, VREGVDD = AVDD = IOVDD = 3.3V. Crystal frequency = 39 MHz. RF Center frequency 912 MHz.

Table 4.10. Sub-GHz RF Transmitter characteristics for 915 MHz Band, +14 dBm

Parameter	Symbol	Test Condition	Min	Typ	Max	Unit
RF tuning frequency range	FRANGE		902	—	930	MHz
Maximum TX Power	POUTMAX	14 dBm output power setting 1 2	—	13.9	—	dBm
Minimum active TX Power	POUTMIN		—	-30	—	dBm
Output power step size	POUTSTEP	output power > 0 dBm	—	0.3	—	dB
Output power variation vs supply at POUTMAX	POUTVAR_V	2.0 V < VVREGVDD < 3.3 V, T = 25 °C 3	—	1.9	—	dB
Output power variation vs temperature, peak to peak	POUTVAR_T	-40 to +85 °C	—	1.1	—	dB
Output power variation vs RF frequency	POUTVAR_F	T = 25 °C, Over specified RF tuning frequency range	—	0.3	—	dB
Spurious emissions of harmonics at +14 dBm output power, Conducted measurement, +14 dBm match, Test Frequency = 912 MHz	SPURHARM_FCC_14	In restricted bands, per FCC 47 CFR §15.205 & §15.209 ⁴⁵	—	-48	-42	dBm
		In non-restricted bands, per FCC 47 CFR §15.247 ⁶	—	-40	-20	dBc
Spurious emissions out-of-band at +14 dB output power, Conducted measurement, +14 dB match, Test Frequency = 912 MHz	SPURROOB_FCC_14	In non-restricted bands, per FCC 47 CFR §15.247 ⁶	—	-66	-20	dBc
		In restricted bands (30-88 MHz), per FCC 47 CFR §15.205 & §15.209 ^{4 5}	—	-58	-46	dBm
		In restricted bands (88-216 MHz), per FCC 47 CFR §15.205 & §15.209 ^{4 5}	—	-68	-56	dBm
		In restricted bands (216-960 MHz), per FCC 47 CFR §15.205 & §15.209 ^{4 5}	—	-61	-52	dBm
		In restricted bands (>960 MHz), per FCC 47 CFR §15.205 & §15.209 ^{4 5}	—	-61	-42	dBm
Power spectral density limit	PSD ₁₄	PSD per FCC Part 15.247, 100 kbps O-QPSK	—	-1.1	—	dBm/3kHz
Error Vector Magnitude, per 802.15.4-2006	EVM	Signal is 100 kbps DSSS-OQPSK reference packet. Modulated according to 802.15.4-2006 OQPSK-BPSK in the 915 MHz band, with pseudo-random packet data content. POUT = +14 dBm.	—	5.0	—	%

Parameter	Symbol	Test Condition	Min	Typ	Max	Unit
Note:						
1. Supported transmit power levels are determined by the ordering part number (OPN). Transmit power ratings for all devices covered in this datasheet can be found in the Max TX Power column of the Ordering Information Table.						
2. The 14 dBm match is optimized for best efficiency at 14 dBm. The maximum output power can go up to the maximum rating. Emissions are tested with the output power set to 14 dBm.						
3. Due to supply current limitations of the DCDC circuit, POUTmax is only achievable at V_VREGVDD > 2.0 V						
4. FCC Title 47 CFR Part 15 Section 15.205 Restricted bands of operation.						
5. FCC Title 47 CFR Part 15 Section 15.209 Radiated emission limits; general requirements						
6. FCC Title 47 CFR Part 15 Section 15.247 Operation within the bands 902-928 MHz, 2400-2483.5 MHz, and 5725-5850 MHz.						

4.1.8.3 Sub-GHz RF Receiver Characteristics for 915 MHz Band

Unless otherwise indicated, typical conditions are: T = 25 °C, VREGVDD = AVDD = IOVDD = 3.3 V. Crystal frequency = 39 MHz. RF frequency band 915 MHz.

Table 4.11. Sub-GHz RF Receiver Characteristics for 915 MHz Band

Parameter	Symbol	Test Condition	Min	Typ	Max	Unit
Tuning frequency range	FRANGE		902	—	930	MHz
Max usable input level, 1% FER	SAT _{100K}	Desired is reference 100 kbps GFSK signal ₁	—	10	—	dBm
Sensitivity _{2 3}	SENS	Desired is reference 100 kbps GFSK signal ₁ , 1% FER, frequency = 916 MHz, T ≤ 85 °C	—	-97.5	—	dBm
		Desired is reference 100 kbps O-QPSK signal ₄ , 1% FER, frequency = 912 MHz, T ≤ 85 °C	—	-103.9	—	dBm
		Desired is reference 40 kbps 2FSK signal ₅ , 1% FER, frequency = 908.4 MHz, T ≤ 85 °C	—	-101.3	—	dBm
		Desired is reference 9.6 kbps 2FSK signal ₆ , 1% FER, frequency = 908.42 MHz, T ≤ 85 °C	—	-102.5	—	dBm
Image rejection, Interferer is CW at image frequency	C/IMAGE	Desired is reference 100 kbps O-QPSK signal ₄ , 1% FER, frequency = 912 MHz	—	40.1	—	dB
		Desired is reference 40 kbps 2FSK signal ₅ at 3dB above sensitivity level, 1% FER, frequency = 908.4 MHz	—	36.2	—	dB
		Desired is 100 kbps GFSK signal ₁ at 3dB above sensitivity level, 1% FER, frequency = 916 MHz	—	34.7	—	dB
		Desired is reference 9.6 kbps 2FSK signal ₆ at 3dB above sensitivity level, 1% FER, frequency = 908.42 MHz	—	36.1	—	dB
Blocking selectivity, 1% FER. Desired is 100 kbps GFSK signal ₁ at 3dB above sensitivity level, frequency = 916 MHz	C/IBLOCKER_100	Interferer CW at Desired ± 1 MHz	—	48.7	—	dB
		Interferer CW at Desired ± 2 MHz	—	54.8	—	dB
		Interferer CW at Desired ± 5 MHz	—	64.1	—	dB
		Interferer CW at Desired ± 10 MHz ₇	—	67.7	—	dB
		Interferer CW at Desired ± 100 MHz ₇	—	78.8	—	dB

Parameter	Symbol	Test Condition	Min	Typ	Max	Unit
Blocking selectivity, 1% FER. Desired is 40 kbps 2FSK signals at 3dB above sensitivity level, frequency = 908.4 MHz	C/IBLOCKER_40	Interferer CW at Desired \pm 1 MHz	—	53.0	—	dB
		Interferer CW at Desired \pm 2 MHz	—	58.9	—	dB
		Interferer CW at Desired \pm 5 MHz	—	71.4	—	dB
		Interferer CW at Desired \pm 10 MHz ⁷	—	79.2	—	dB
		Interferer CW at Desired \pm 100 MHz ⁷	—	82.8	—	dB
Blocking selectivity, 1% FER. Desired is 9.6 kbps 2FSK signal ⁶ at 3dB above sensitivity level, frequency = 908.42 MHz	C/IBLOCKER_9p6	Interferer CW at Desired \pm 1 MHz	—	54.2	—	dB
		Interferer CW at Desired \pm 2 MHz	—	62.9	—	dB
		Interferer CW at Desired \pm 5 MHz	—	72.4	—	dB
		Interferer CW at Desired \pm 10 MHz ⁷	—	80.4	—	dB
		Interferer CW at Desired \pm 100 MHz ⁷	—	84.0	—	dB
Blocking selectivity, 1% FER. Desired is reference 100 kbps O-QPSK signal ⁴ at -89 dBm level 1% FER, frequency = 912 MHz	C/IBLOCKER_OQPSK	Interferer CW at Desired \pm 2 MHz	—	54.2	—	dB
		Interferer CW at Desired \pm 5 MHz	—	59.4	—	dB
		Interferer CW at Desired \pm 10 MHz	—	67.0	—	dB
		Interferer CW at Desired \pm 100 MHz	—	78.9	—	dB
Intermod selectivity, 1% FER. CW interferers at 400 kHz and 800 kHz offsets	C/IIM	Desired is 100 kbps GFSK signal ¹ at 3dB above sensitivity level, frequency = 916 MHz	—	31.6	—	dB
Upper limit of input power range over which RSSI resolution is maintained	RSSI _{MAX}		—	—	5	dBm
Lower limit of input power range over which RSSI resolution is maintained	RSSI _{MIN}		-98	—	—	dBm
RSSI resolution	RSSI _{RES}	Over RSSI _{MIN} to RSSI _{MAX} range	—	0.25	—	dBm
Max spurious emissions during active receive mode, per FCC Part 15.109(a)	SPURRX_FCC	216-960 MHz	—	-82.25	-49.2	dBm
		Above 960 MHz	—	-68.41	-41.2	dBm
Max spurious emissions during active receive mode, per ARIB STD-T108 Section 3.3	SPURRX_ARIB	Below 710 MHz, RBW=100kHz	—	-69.17	-54	dBm
		710-900 MHz, RBW=1MHz	—	-71.76	-55	dBm
		900-915 MHz, RBW=100kHz	—	-72.55	-55	dBm
		915-930 MHz, RBW=100kHz	—	-73.07	-55	dBm
		930-1000 MHz, RBW=100kHz	—	-72.84	-55	dBm
		Above 1000 MHz, RBW=1MHz	—	-71.49	-47	dBm

Parameter	Symbol	Test Condition	Min	Typ	Max	Unit
Note:						
1. Definition of reference signal is 100 kbps 2GFSK, BT=0.6, $\Delta f = 58$ kHz, NRZ, '0' = $F_{center} + \Delta f/2$, '1' = $F_{center} - \Delta f/2$						
2. Minimum Packet Error Rate floor will be ~0.5% for desired input signal levels between specified datasheet sensitivity level and -10dBm.						
3. Minimum Packet Error Rate floor will be ~ 1% for desired input signal levels > -10dBm.						
4. Definition of reference signals is 100 kbps O-QPSK, 800 kbps chip rate, 8x spreading factor, 32 bit chip length, 4 bits per symbol						
5. Definition of reference signal is 40 kbps 2FSK, $\Delta f = 40$ kHz, NRZ, '0' = $F_{center} + \Delta f/2$, '1' = $F_{center} - \Delta f/2$						
6. Definition of reference signal is 9.6 kbps 2FSK, $\Delta f = 40$ kHz, Manchester, '0' = Transition from ($F_{center} + 20k + \Delta f/2$), '1' = Transition from ($F_{center} + 20k - \Delta f/2$)						
7. Minimum Packet Error Rate floor for signals in presence of blocker will increase above 1% for blocker levels above -30dBm.						

4.1.8.4 Sub-GHz RF Transmitter characteristics for 868 MHz Band

Unless otherwise indicated, typical conditions are: T = 25 °C, VREGVDD = AVDD = IOVDD = 3.3 V. Crystal frequency = 39 MHz. RF frequency band 868 MHz.

Table 4.12. Sub-GHz RF Transmitter characteristics for 868 MHz Band

Parameter	Symbol	Test Condition	Min	Typ	Max	Unit
RF tuning frequency range	FRANGE		863	—	876	MHz
Maximum TX Power ¹	POUTMAX	13 dBm output power setting	—	13	—	dBm
Minimum active TX Power	POUTMIN		—	-30	—	dBm
Output power step size	POUTSTEP	output power > 0 dBm	—	0.5	—	dB
Output power variation vs supply at POUTMAX	POUTVAR_V	1.8 V < VVREGVDD < 3.3 V, T = 25 °C	—	2.6	—	dB
Output power variation vs temperature, peak to peak	POUTVAR_T	-40 to +85 °C	—	1.4	—	dB
Output power variation vs RF frequency	POUTVAR_F	T = 25 °C, Over specified RF tuning frequency range	—	0.5	—	dB
Spurious emissions of harmonics, Conducted measurement, Test Frequency = 868.4 MHz	SPURHARM_ETSI	Per ETSI EN 300-220, Section 7.8.2.1	—	-39	-30	dBm
Spurious emissions out-of-band, Conducted measurement, Test Frequency = 868.4 MHz	SPUROOB_ETSI	Per ETSI EN 300-220, Section 7.8.2.1 (47-74 MHz, 87.5-118 MHz, 174-230 MHz, and 470-862 MHz)	—	-69	-54	dBm
		Per ETSI EN 300-220, Section 7.8.2.1 (other frequencies below 1 GHz)	—	-70	-36	dBm
		Per ETSI EN 300-220, Section 7.8.2.1 (frequencies above 1 GHz)	—	-66	-30	dBm

Note:

1. If a SAW filter is used, the output power is 2 - 3 dBm lower due to insertion loss. Always adjust the output power to match the limits set by the RF regulatory authorities for the region in which the device is used.

4.1.8.5 Sub-GHz RF Receiver Characteristics for 868 MHz Band

Unless otherwise indicated, typical conditions are: T = 25 °C, VREGVDD = AVDD = IOVDD = 3.3 V. Crystal frequency = 39 MHz. RF frequency band 868 MHz.

Table 4.13. Sub-GHz RF Receiver Characteristics for 868 MHz Band

Parameter	Symbol	Test Condition	Min	Typ	Max	Unit
Tuning frequency range	FRANGE		863	—	876	MHz
Max usable input level, 1% FER	SAT _{100k}	Desired is reference 100 kbps GFSK signal ₁	—	10	—	dBm
Sensitivity _{2 3}	SENS	Desired is reference 100 kbps GFSK signal ₁ , 1% FER, frequency = 869.85 MHz, T ≤ 85 °C	—	-97.9	—	dBm
		Desired is reference 40 kbps 2FSK signal ₄ , 1% FER, frequency = 868.4 MHz, T ≤ 85 °C	—	-101.5	—	dBm
		Desired is reference 9.6 kbps 2FSK signal ₅ , 1% FER, frequency = 868.42 MHz, T ≤ 85 °C	—	-102.6	—	dBm
Image rejection, Interferer is CW at image frequency	C/IIMAGE	Desired is 100kbps GFSK signal ₁ at 3dB above sensitivity level, 1% FER, frequency = 869.85 MHz	—	33.4	—	dB
		Desired is reference 40 kbps 2FSK signal ₄ at 3dB above sensitivity level, 1% FER, frequency = 868.4 MHz	—	34.5	—	dB
		Desired is reference 9.6 kbps 2FSK signal ₅ at 3dB above sensitivity level, 1% FER, frequency = 868.42 MHz	—	35.3	—	dB
Blocking selectivity, 1% FER. Desired is 100 kbps GFSK signal ₁ at 3 dB above sensitivity level, frequency = 869.85 MHz	C/IBLOCKER_100	Interferer CW at Desired ± 1 MHz	—	49.6	—	dB
		Interferer CW at Desired ± 2 MHz	—	55.6	—	dB
		Interferer CW at Desired ± 5 MHz	—	68.1	—	dB
		Interferer CW at Desired ± 10 MHz ₆	—	75.1	—	dB
		Interferer CW at Desired ± 100 MHz ₆	—	77.4	—	dB
Blocking selectivity, 1% FER. Desired is 40 kbps 2FSK signal ₄ at 3 dB above sensitivity level, frequency = 868.4 MHz	C/IBLOCKER_40	Interferer CW at Desired ± 1 MHz	—	53.4	—	dB
		Interferer CW at Desired ± 2 MHz	—	59.8	—	dB
		Interferer CW at Desired ± 5 MHz	—	71.9	—	dB
		Interferer CW at Desired ± 10 MHz ₆	—	79.5	—	dB
		Interferer CW at Desired ± 100 MHz ₆	—	81.1	—	dB

Parameter	Symbol	Test Condition	Min	Typ	Max	Unit
Blocking selectivity, 1% FER. Desired is 9.6 kbps 2FSK signals at 3 dB above sensitivity level, frequency = 868.42 MHz	C/IBLOCKER_9p6	Interferer CW at Desired \pm 1 MHz	—	54.8	—	dB
		Interferer CW at Desired \pm 2 MHz	—	60.7	—	dB
		Interferer CW at Desired \pm 5 MHz	—	72.8	—	dB
		Interferer CW at Desired \pm 10 MHz ⁶	—	80.3	—	dB
		Interferer CW at Desired \pm 100 MHz ⁶	—	82.1	—	dB
Upper limit of input power range over which RSSI resolution is maintained	RSSI _{MAX}		—	—	5	dBm
Lower limit of input power range over which RSSI resolution is maintained	RSSI _{MIN}		-98	—	—	dBm
RSSI resolution	RSSI _{RES}	Over RSSI _{MIN} to RSSI _{MAX} range	—	0.25	—	dBm
Max spurious emissions during active receive mode	SPUR _{RX}	30 MHz to 1 GHz	—	-67.46	-57	dBm
		1 GHz to 12 GHz	—	-69.7	-47	dBm

Note:

1. Definition of reference signal is 100 kbps 2GFSK, BT=0.6, $\Delta f = 58$ kHz, NRZ, '0' = $F_{center} + \Delta f/2$, '1' = $F_{center} - \Delta f/2$
2. Minimum Packet Error Rate floor will be ~0.5% for desired input signal levels between specified datasheet sensitivity level and -10dBm.
3. Minimum Packet Error Rate floor will be ~ 1% for desired input signal levels > -10dBm.
4. Definition of reference signal is 40 kbps 2FSK, $\Delta f = 40$ kHz, NRZ, '0' = $F_{center} + \Delta f/2$, '1' = $F_{center} - \Delta f/2$
5. Definition of reference signal is 9.6 kbps 2FSK, $\Delta f = 40$ kHz, Manchester, '0' = Transition from ($F_{center} + 20k + \Delta f/2$), '1' = Transition from ($F_{center} + 20k - \Delta f/2$)
6. Minimum Packet Error Rate floor for signals in presence of blocker will increase above 1% for blocker levels above -30dBm.

4.1.9 Oscillators

4.1.9.1 High-Frequency Crystal Oscillator (HFXO)

Internal crystal = TXC P/N 8Y39072002

Table 4.14. High-Frequency Crystal Oscillator (HFXO)

Parameter	Symbol	Test Condition	Min	Typ	Max	Unit
Crystal frequency	f _{HFXO}	39 MHz required for radio transceiver operation	—	39	—	MHz
Calibrated precision	PRE _{CHFXO}		-2	—	2	ppm
5-year aging	AGING _{HFXO}		-3	—	3	ppm
Temperature drift	DRIFT _{HFXO}	-40 °C to 85 °C	-13	—	13	ppm

4.1.9.2 Low-Frequency RC Oscillator (LFRCO)

Table 4.15. Low-Frequency RC Oscillator (LFRCO)

Parameter	Symbol	Test Condition	Min	Typ	Max	Unit
Oscillation frequency	f _{LFRCO}	ENVREF ₁ = 1	31.3	32.768	33.6	kHz
		ENVREF ₁ = 0	31.3	32.768	33.4	kHz
Startup time	t _{LFRCO}		—	500	—	µs
Current consumption 2	I _{LFRCO}	ENVREF = 1 in CMU_LFRCOCTRL	—	342	—	nA
		ENVREF = 0 in CMU_LFRCOCTRL	—	494	—	nA
Note:						
1. In CMU_LFRCOCTRL register.						
2. Block is supplied by AVDD if ANASW = 0, or DVDD if ANASW=1 in EMU_PWRCTRL register.						

4.1.9.3 High-Frequency RC Oscillator (HFRCO)

Table 4.16. High-Frequency RC Oscillator (HFRCO)

Parameter	Symbol	Test Condition	Min	Typ	Max	Unit
Frequency accuracy	fHFRCO_ACC	At production calibrated frequencies, across supply voltage and temperature	-2.5	—	2.5	%
Start-up time	tHFRCO	fHFRCO ≥ 19 MHz	—	300	—	ns
		4 < fHFRCO < 19 MHz	—	1	—	μs
		fHFRCO ≤ 4 MHz	—	2.5	—	μs
Current consumption on all supplies	IHFRCO	fHFRCO = 38 MHz	—	267	299	μA
		fHFRCO = 32 MHz	—	224	248	μA
		fHFRCO = 26 MHz	—	189	211	μA
		fHFRCO = 19 MHz	—	154	172	μA
		fHFRCO = 16 MHz	—	133	148	μA
		fHFRCO = 13 MHz	—	118	135	μA
		fHFRCO = 7 MHz	—	89	100	μA
		fHFRCO = 4 MHz	—	34	44	μA
		fHFRCO = 2 MHz	—	29	40	μA
		fHFRCO = 1 MHz	—	26	36	μA
Coarse trim step size (% of period)	SSHFRCO_COARSE		—	0.8	—	%
Fine trim step size (% of period)	SSHFRCO_FINE		—	0.1	—	%
Period jitter	PJHFRCO		—	0.2	—	% RMS
Frequency limits	fHFRCO_BAND	FREQRANGE = 0, FINETUNING = 0	3.47	—	6.15	MHz
		FREQRANGE = 3, FINETUNING = 0	6.24	—	11.45	MHz
		FREQRANGE = 6, FINETUNING = 0	11.3	—	19.8	MHz
		FREQRANGE = 7, FINETUNING = 0	13.45	—	22.8	MHz
		FREQRANGE = 8, FINETUNING = 0	16.5	—	29.0	MHz
		FREQRANGE = 10, FINETUNING = 0	23.11	—	40.63	MHz
		FREQRANGE = 11, FINETUNING = 0	27.27	—	48	MHz
		FREQRANGE = 12, FINETUNING = 0	33.33	—	54	MHz

4.1.9.4 Ultra-low Frequency RC Oscillator (ULFRCO)

Table 4.17. Ultra-low Frequency RC Oscillator (ULFRCO)

Parameter	Symbol	Test Condition	Min	Typ	Max	Unit
Oscillation frequency	fULFRCO		0.95	1	1.07	kHz

4.1.10 Flash Memory Characteristics¹

Table 4.18. Flash Memory Characteristics¹

Parameter	Symbol	Test Condition	Min	Typ	Max	Unit
Flash erase cycles before failure	ECFLASH		10000	—	—	cycles
Flash data retention	RETFLASH		10	—	—	years
Word (32-bit) programming time	tw_PROG	Burst write, 128 words, average time per word	20	26.3	30	μs
		Single word	62	68.9	80	μs
Page erase time ²	tPERASE		20	29.5	40	ms
Mass erase time ³	tMERASE		20	30	40	ms
Device erase time ^{4 5}	tDERASE		—	56.2	70	ms
Erase current ⁶	I _{ERASE}	Page Erase	—	—	2.0	mA
Write current ⁶	I _{WRITE}		—	—	3.5	mA
Supply voltage during flash erase and write	VFLASH		1.62	—	3.6	V

Note:

1. Flash data retention information is published in the Quarterly Quality and Reliability Report.
2. From setting the ERASEPAGE bit in MSC_WRITECMD to 1 until the BUSY bit in MSC_STATUS is cleared to 0. Internal setup and hold times for flash control signals are included.
3. Mass erase is issued by the CPU and erases all flash.
4. Device erase is issued over the AAP interface and erases all flash, SRAM, the Lock Bit (LB) page, and the User data page Lock Word (ULW).
5. From setting the DEVICEERASE bit in AAP_CMD to 1 until the ERASEBUSY bit in AAP_STATUS is cleared to 0. Internal setup and hold times for flash control signals are included.
6. Measured at 25 °C.

4.1.11 General-Purpose I/O (GPIO)

Table 4.19. General-Purpose I/O (GPIO)

Parameter	Symbol	Test Condition	Min	Typ	Max	Unit
Input low voltage ¹	V _{IL}	GPIO pins	—	—	IOVDD*0.3	V
		RESET _n	—	—	AVDD*0.3	V
Input high voltage ¹	V _{IH}	GPIO pins	IOVDD*0.7	—	—	V
		RESET _n	AVDD*0.7	—	—	V
Output high voltage relative to IOVDD	V _{OH}	Sourcing 3 mA, IOVDD ≥ 3 V, DRIVESTRENGTH ₂ = WEAK	IOVDD*0.8	—	—	V
		Sourcing 1.2 mA, IOVDD ≥ 1.62 V, DRIVESTRENGTH ₂ = WEAK	IOVDD*0.6	—	—	V
		Sourcing 20 mA, IOVDD ≥ 3 V, DRIVESTRENGTH ₂ = STRONG	IOVDD*0.8	—	—	V
		Sourcing 8 mA, IOVDD ≥ 1.62 V, DRIVESTRENGTH ₂ = STRONG	IOVDD*0.6	—	—	V
Output low voltage relative to IOVDD	V _{OL}	Sinking 3 mA, IOVDD ≥ 3 V, DRIVESTRENGTH ₂ = WEAK	—	—	IOVDD*0.2	V
		Sinking 1.2 mA, IOVDD ≥ 1.62 V, DRIVESTRENGTH ₂ = WEAK	—	—	IOVDD*0.4	V
		Sinking 20 mA, IOVDD ≥ 3 V, DRIVESTRENGTH ₂ = STRONG	—	—	IOVDD*0.2	V
		Sinking 8 mA, IOVDD ≥ 1.62 V, DRIVESTRENGTH ₂ = STRONG	—	—	IOVDD*0.4	V
Input leakage current	I _{IOLEAK}	All GPIO pins except PB14 and PB15, GPIO ≤ IOVDD	—	0.1	30	nA
		PB14 and PB15, GPIO ≤ IOVDD	—	0.1	50	nA
Input leakage current on 5VTOL pads above IOVDD	I _{5VTOLLEAK}	IOVDD < GPIO ≤ IOVDD + 2 V	—	3.3	15	μA
I/O pin pull-up/pull-down resistor ³	RPUD		30	40	65	kΩ
Pulse width of pulses removed by the glitch suppression filter	t _{IOGLITCH}		15	25	45	ns

Parameter	Symbol	Test Condition	Min	Typ	Max	Unit
Output fall time, From 70% to 30% of V _{IO}	tIOF	CL = 50 pF, DRIVESTRENGTH ₂ = STRONG, SLEWRATE ₂ = 0x6	—	1.8	—	ns
		CL = 50 pF, DRIVESTRENGTH ₂ = WEAK, SLEWRATE ₂ = 0x6	—	4.5	—	ns
Output rise time, From 30% to 70% of V _{IO}	tIOOR	CL = 50 pF, DRIVESTRENGTH ₂ = STRONG, SLEWRATE = 0x62	—	2.2	—	ns
		CL = 50 pF, DRIVESTRENGTH ₂ = WEAK, SLEWRATE ₂ = 0x6	—	7.4	—	ns
RESET _n low time to ensure pin reset	TRESET		100	—	—	ns

Note:

1. GPIO input threshold are proportional to the IOVDD supply, except for RESET_n which is proportional to AVDD.
2. In GPIO_Pn_CTRL register.
3. GPIO pull-ups are referenced to the IOVDD supply, except for RESET_n, which connects to AVDD.

4.1.12 Voltage Monitor (VMON)

Table 4.20. Voltage Monitor (VMON)

Parameter	Symbol	Test Condition	Min	Typ	Max	Unit
Supply current (including I_SENSE)	IVMON	In EM0 or EM1, 1 active channel	—	6.3	8	μA
		In EM0 or EM1, All channels active	—	12.5	15	μA
		In EM2, EM3 or EM4, 1 channel active and above threshold	—	62	—	nA
		In EM2, EM3 or EM4, 1 channel active and below threshold	—	62	—	nA
		In EM2, EM3 or EM4, All channels active and above threshold	—	99	—	nA
		In EM2, EM3 or EM4, All channels active and below threshold	—	99	—	nA
Loading of monitored supply	ISENSE	In EM0 or EM1	—	2	—	μA
		In EM2, EM3 or EM4	—	2	—	nA
Threshold range	VVMON_RANGE		1.62	—	3.4	V
Threshold step size	NVMON_STESP	Coarse	—	200	—	mV
		Fine	—	20	—	mV
Response time	tVMON_RES	Supply drops at 1V/μs rate	—	460	—	ns
Hysteresis	VVMON_HYST		—	26	—	mV

4.1.13 Analog to Digital Converter (ADC)

Specified at 1 Msps, ADCCLK = 16 MHz, BIASPROG = 0, GPBIASACC = 0, unless otherwise indicated.

Table 4.21. Analog to Digital Converter (ADC)

Parameter	Symbol	Test Condition	Min	Typ	Max	Unit
Resolution	VRESOLUTION		6	—	12	Bits
Input voltage range ¹	VADCIN	Single ended	—	—	VFS	V
		Differential	-VFS/2	—	VFS/2	V
Input range of external reference voltage, single ended and differential	VADCREFIN_P		1	—	VAVDD	V
Power supply rejection ²	PSRRADC	At DC	—	80	—	dB
Analog input common mode rejection ratio	CMRRADC	At DC	—	80	—	dB
Current from all supplies, using internal reference buffer. Continuous operation. WAR- MUPMODE ₃ = KEEPADC- WARM	IADC_CONTINU- OUS_LP	1 Msps / 16 MHz ADCCLK, BIA- SPROG = 0, GPBIASACC = 1 4	—	270	290	μA
		250 ksps / 4 MHz ADCCLK, BIA- SPROG = 6, GPBIASACC = 1 4	—	125	—	μA
		62.5 ksps / 1 MHz ADCCLK, BIA- SPROG = 15, GPBIASACC = 1 4	—	80	—	μA
Current from all supplies, using internal reference buffer. Duty-cycled operation. WAR- MUPMODE ₃ = NORMAL	IADC_NORMAL_LP	35 ksps / 16 MHz ADCCLK, BIA- SPROG = 0, GPBIASACC = 1 4	—	45	—	μA
		5 ksps / 16 MHz ADCCLK BIA- SPROG = 0, GPBIASACC = 1 4	—	8	—	μA
Current from all supplies, using internal reference buffer. Duty-cycled operation. AWARMUPMODE ₃ = KEEP- INSTANDBY or KEEPIN- SLOWACC	IADC_STAND- BY_LP	125 ksps / 16 MHz ADCCLK, BIA- SPROG = 0, GPBIASACC = 1 4	—	105	—	μA
		35 ksps / 16 MHz ADCCLK, BIA- SPROG = 0, GPBIASACC = 1 4	—	70	—	μA
Current from all supplies, using internal reference buffer. Continuous operation. WAR- MUPMODE ₃ = KEEPADC- WARM	IADC_CONTINU- OUS_HP	1 Msps / 16 MHz ADCCLK, BIA- SPROG = 0, GPBIASACC = 0 4	—	325	—	μA
		250 ksps / 4 MHz ADCCLK, BIA- SPROG = 6, GPBIASACC = 0 4	—	175	—	μA
		62.5 ksps / 1 MHz ADCCLK, BIA- SPROG = 15, GPBIASACC = 0 4	—	125	—	μA
Current from all supplies, using internal reference buffer. Duty-cycled operation. WAR- MUPMODE ₃ = NORMAL	IADC_NORMAL_HP	35 ksps / 16 MHz ADCCLK, BIA- SPROG = 0, GPBIASACC = 0 4	—	85	—	μA
		5 ksps / 16 MHz ADCCLK BIA- SPROG = 0, GPBIASACC = 0 4	—	16	—	μA
Current from all supplies, using internal reference buffer. Duty-cycled operation. AWARMUPMODE ₃ = KEEP- INSTANDBY or KEEPIN- SLOWACC	IADC_STAND- BY_HP	125 ksps / 16 MHz ADCCLK, BIA- SPROG = 0, GPBIASACC = 0 4	—	160	—	μA
		35 ksps / 16 MHz ADCCLK, BIA- SPROG = 0, GPBIASACC = 0 4	—	125	—	μA
Current from HUPERCLK	IADC_CLK	HUPERCLK = 16 MHz	—	140	—	μA

Parameter	Symbol	Test Condition	Min	Typ	Max	Unit
ADC clock frequency	f _{ADCCLK}		—	—	16	MHz
Throughput rate	f _{ADCRATE}		—	—	1	Msp/s
Conversion times	t _{ADCCONV}	6 bit	—	7	—	cycles
		8 bit	—	9	—	cycles
		12 bit	—	13	—	cycles
Startup time of reference generator and ADC core	t _{ADCSTART}	WARMUPMODE ₃ = NORMAL	—	—	5	μs
		WARMUPMODE ₃ = KEEPIN-STANDBY	—	—	2	μs
		WARMUPMODE ₃ = KEEPINSLOWACC	—	—	1	μs
SNDR at 1Msp/s and f _{IN} = 10kHz	SNDR _{ADC}	Internal reference ⁶ , differential measurement	58	67	—	dB
		External reference ⁷ , differential measurement	—	68	—	dB
Spurious-free dynamic range (SFDR)	SFDR _{ADC}	1 MSamples/s, 10 kHz full-scale sine wave	—	75	—	dB
Differential non-linearity (DNL)	DNL _{ADC}	12 bit resolution, No missing codes	-1	—	2	LSB
Integral non-linearity (INL), End point method	INL _{ADC}	12 bit resolution	-6	—	6	LSB
Offset error	V _{ADCOFFSETERR}		-3	0	3	LSB
Gain error in ADC	V _{ADCGAIN}	Using internal reference	—	-0.2	3.5	%
		Using external reference	—	-1	—	%
Temperature sensor slope	V _{TS_SLOPE}		—	-1.84	—	mV/°C

Note:

1. The absolute voltage allowed at any ADC input is dictated by the power rail supplied to on-chip circuitry, and may be lower than the effective full scale voltage. All ADC inputs are limited to the ADC supply (AVDD or DVDD depending on EMU_PWRCTRL_ANASW). Any ADC input routed through the APORT will further be limited by the IOVDD supply to the pin.
2. PSRR is referenced to AVDD when ANASW=0 and to DVDD when ANASW=1 in EMU_PWRCTRL.
3. In ADCn_CTRL register.
4. In ADCn_BIASPROG register.
5. Derived from ADCCLK.
6. Internal reference option used corresponds to selection 2V5 in the SINGLECTRL_REF or SCANCTRL_REF register field. The differential input range with this configuration is ± 1.25 V. Typical value is characterized using full-scale sine wave input. Minimum value is production-tested using sine wave input at 1.5 dB lower than full scale.
7. External reference is 1.25 V applied externally to ADCnEXTREFP, with the selection CONF in the SINGLECTRL_REF or SCANCTRL_REF register field and VREFP in the SINGLECTRLX_VREFSEL or SCANCTRLX_VREFSEL field. The differential input range with this configuration is ± 1.25 V.

4.1.14 Analog Comparator (ACMP)

Table 4.22. Analog Comparator (ACMP)

Parameter	Symbol	Test Condition	Min	Typ	Max	Unit
Input voltage range	VACMPIN	ACMPVDD = ACMPn_CTRL_PWRSEL 1	—	—	VACMPVDD	V
Supply voltage	VACMPVDD	BIASPROG ₂ ≤ 0x10 or FULL- BIAS ₂ = 0	1.8	—	VVREGVDD_ MAX	V
		0x10 < BIASPROG ₂ ≤ 0x20 and FULLBIAS ₂ = 1	2.1	—	VVREGVDD_ MAX	V
Active current not including voltage reference ³	IACMP	BIASPROG ₂ = 0x10, FULLBIAS ₂ = 0	—	306	—	nA
		BIASPROG ₂ = 0x02, FULLBIAS ₂ = 1	—	6.1	11	μA
		BIASPROG ₂ = 0x20, FULLBIAS ₂ = 1	—	74	92	μA
Current consumption of internal voltage reference ³	IACMPREF	VLP selected as input using 2.5 V Reference / 4 (0.625 V)	—	50	—	nA
		VLP selected as input using VDD	—	20	—	nA
		VBDIV selected as input using 1.25 V reference / 1	—	4.1	—	μA
		VADIV selected as input using VDD/1	—	2.4	—	μA
Hysteresis (V _{CM} = 1.25 V, BIASPROG ₂ = 0x10, FULL- BIAS ₂ = 1)	VACMPHYST	HYSTSEL ₄ = HYST0	-3	0	3	mV
		HYSTSEL ₄ = HYST1	5	18	27	mV
		HYSTSEL ₄ = HYST2	12	33	50	mV
		HYSTSEL ₄ = HYST3	17	46	67	mV
		HYSTSEL ₄ = HYST4	23	57	86	mV
		HYSTSEL ₄ = HYST5	26	68	104	mV
		HYSTSEL ₄ = HYST6	30	79	130	mV
		HYSTSEL ₄ = HYST7	34	90	155	mV
		HYSTSEL ₄ = HYST8	-3	0	3	mV
		HYSTSEL ₄ = HYST9	-27	-18	-5	mV
		HYSTSEL ₄ = HYST10	-50	-33	-12	mV
		HYSTSEL ₄ = HYST11	-67	-45	-17	mV
		HYSTSEL ₄ = HYST12	-86	-57	-23	mV
		HYSTSEL ₄ = HYST13	-104	-67	-26	mV
		HYSTSEL ₄ = HYST14	-130	-78	-30	mV
HYSTSEL ₄ = HYST15	-155	-88	-34	mV		

Parameter	Symbol	Test Condition	Min	Typ	Max	Unit
Comparator delay ⁵	tACMPDELAY	BIASPROG ₂ = 0x10, FULLBIAS ₂ = 0	—	3.7	10	µs
		BIASPROG ₂ = 0x02, FULLBIAS ₂ = 1	—	360	1000	ns
		BIASPROG ₂ = 0x20, FULLBIAS ₂ = 1	—	35	—	ns
Offset voltage	VACMPOFFSET	BIASPROG ₂ = 0x10, FULLBIAS ₂ = 1	-35	—	35	mV
Reference voltage	VACMPREF	Internal 1.25 V reference	1	1.25	1.47	V
		Internal 2.5 V reference	1.98	2.5	2.8	V
Capacitive sense internal resistance	RCSRES	CSRESSEL ₆ = 0	—	infinite	—	kΩ
		CSRESSEL ₆ = 1	—	15	—	kΩ
		CSRESSEL ₆ = 2	—	27	—	kΩ
		CSRESSEL ₆ = 3	—	39	—	kΩ
		CSRESSEL ₆ = 4	—	51	—	kΩ
		CSRESSEL ₆ = 5	—	102	—	kΩ
		CSRESSEL ₆ = 6	—	164	—	kΩ
		CSRESSEL ₆ = 7	—	239	—	kΩ

Note:

- 1.ACMPVDD is a supply chosen by the setting in ACMPn_CTRL_PWRSEL and may be IOVDD, AVDD or DVDD.
- 2.In ACMPn_CTRL register.
- 3.The total ACMP current is the sum of the contributions from the ACMP and its internal voltage reference. IACMPTOTAL = IACMP + IACMPREF.
- 4.In ACMPn_HYSTERESIS registers.
- 5.± 100 mV differential drive.
- 6.In ACMPn_INPUTSEL register.

4.1.15 Digital to Analog Converter (VDAC)

DRIVESTRENGTH = 2 unless otherwise specified. Primary VDAC output.

Table 4.23. Digital to Analog Converter (VDAC)

Parameter	Symbol	Test Condition	Min	Typ	Max	Unit
Output voltage	VDACOUT	Single-Ended	0	—	VVREF	V
		Differential ¹	-VVREF	—	VVREF	V
Current consumption including references (2 channels) ²	IDAC	500 ksps, 12-bit, DRIVESTRENGTH = 2, REFSEL = 4	—	396	—	μA
		44.1 ksps, 12-bit, DRIVESTRENGTH = 1, REFSEL = 4	—	72	—	μA
		200 Hz refresh rate, 12-bit Sample-Off mode in EM2, DRIVESTRENGTH = 2, REFSEL = 4, SETTLETIME = 0x02, WARMUP-TIME = 0x0A	—	1.2	—	μA
Current from HFPERCLK ³	IDAC_CLK		—	5.8	—	μA/MHz
Sample rate	SRDAC		—	—	500	ksps
DAC clock frequency	fDAC		—	—	1	MHz
Conversion time	tDACCONV	fDAC = 1MHz	2	—	—	μs
Settling time	tDACSETTLE	50% fs step settling to 5 LSB	—	2.5	—	μs
Startup time	tDACSTARTUP	Enable to 90% fs output, settling to 10 LSB	—	—	12	μs
Output impedance	ROUT	DRIVESTRENGTH = 2, 0.4 V ≤ VOUT ≤ VOPA - 0.4 V, -8 mA < IOUT < 8 mA, Full supply range	—	2	—	Ω
		DRIVESTRENGTH = 0 or 1, 0.4 V ≤ VOUT ≤ VOPA - 0.4 V, -400 μA < IOUT < 400 μA, Full supply range	—	2	—	Ω
		DRIVESTRENGTH = 2, 0.1 V ≤ VOUT ≤ VOPA - 0.1 V, -2 mA < IOUT < 2 mA, Full supply range	—	2	—	Ω
		DRIVESTRENGTH = 0 or 1, 0.1 V ≤ VOUT ≤ VOPA - 0.1 V, -100 μA < IOUT < 100 μA, Full supply range	—	2	—	Ω
Power supply rejection ratio ⁴	PSRR	Vout = 50% fs. DC	—	65.5	—	dB

Parameter	Symbol	Test Condition	Min	Typ	Max	Unit
Signal to noise and distortion ratio (1 kHz sine wave), Noise band limited to 250 kHz	SNDR _{DAC}	500 ksps, single-ended, internal 1.25V reference	—	60.4	—	dB
		500 ksps, single-ended, internal 2.5V reference	—	61.6	—	dB
		500 ksps, single-ended, 3.3V VDD reference	—	64.0	—	dB
		500 ksps, differential, internal 1.25V reference	—	63.3	—	dB
		500 ksps, differential, internal 2.5V reference	—	64.4	—	dB
		500 ksps, differential, 3.3V VDD reference	—	65.8	—	dB
Signal to noise and distortion ratio (1 kHz sine wave), Noise band limited to 22 kHz	SNDR _{DAC_BAND}	500 ksps, single-ended, internal 1.25V reference	—	65.3	—	dB
		500 ksps, single-ended, internal 2.5V reference	—	66.7	—	dB
		500 ksps, single-ended, 3.3V VDD reference	—	70.0	—	dB
		500 ksps, differential, internal 1.25V reference	—	67.8	—	dB
		500 ksps, differential, internal 2.5V reference	—	69.0	—	dB
		500 ksps, differential, 3.3V VDD reference	—	68.5	—	dB
Total harmonic distortion	THD		—	70.2	—	dB
Differential non-linearity ⁵	DNL _{DAC}		-0.99	—	1	LSB
Integral non-linearity	INL _{DAC}		-4	—	4	LSB
Offset error ⁶	V _{OFFSET}	T = 25 °C	-8	—	8	mV
		Across operating temperature range	-25	—	25	mV
Gain error ⁶	V _{GAIN}	T = 25 °C, Low-noise internal reference (REFSEL = 1V25LN or 2V5LN)	-2.5	—	2.5	%
		T = 25 °C, Internal reference (REFSEL = 1V25 or 2V5)	-5	—	5	%
		T = 25 °C, External reference (REFSEL = VDD or EXT)	-1.8	—	1.8	%
		Across operating temperature range, Low-noise internal reference (REFSEL = 1V25LN or 2V5LN)	-3.5	—	3.5	%
		Across operating temperature range, Internal reference (REFSEL = 1V25 or 2V5)	-7.5	—	7.5	%
		Across operating temperature range, External reference (REFSEL = VDD or EXT)	-2.0	—	2.0	%

Parameter	Symbol	Test Condition	Min	Typ	Max	Unit
External load capacitance, OUTSCALE=0	CLOAD		—	—	75	pF

Note:

1. In differential mode, the output is defined as the difference between two single-ended outputs. Absolute voltage on each output is limited to the single-ended range.
2. Supply current specifications are for VDAC circuitry operating with static output only and do not include current required to drive the load.
3. Current from HUPERCLK is dependent on HUPERCLK frequency. This current contributes to the total supply current used when the clock to the DAC peripheral is enabled in the CMU.
4. PSRR calculated as $20 * \log_{10}(\Delta V_{DD} / \Delta V_{OUT})$, VDAC output at 90% of full scale
5. Entire range is monotonic and has no missing codes.
6. Gain is calculated by measuring the slope from 10% to 90% of full scale. Offset is calculated by comparing actual VDAC output at 10% of full scale to ideal VDAC output at 10% of full scale with the measured gain.

4.1.16 Current Digital to Analog Converter (IDAC)

Table 4.24. Current Digital to Analog Converter (IDAC)

Parameter	Symbol	Test Condition	Min	Typ	Max	Unit
Number of ranges	NIDAC_RANGES		—	4	—	ranges
Output current	IIDAC_OUT	RANGESEL ₁ = RANGE0	0.05	—	1.6	μA
		RANGESEL ₁ = RANGE1	1.6	—	4.7	μA
		RANGESEL ₁ = RANGE2	0.5	—	16	μA
		RANGESEL ₁ = RANGE3	2	—	64	μA
Linear steps within each range	NIDAC_STEPS		—	32	—	steps
Step size	SSIDAC	RANGESEL ₁ = RANGE0	—	50	—	nA
		RANGESEL ₁ = RANGE1	—	100	—	nA
		RANGESEL ₁ = RANGE2	—	500	—	nA
		RANGESEL ₁ = RANGE3	—	2	—	μA
Total accuracy, STEPSEL ₁ = 0x10	ACCIDAC	EM0 or EM1, AVDD=3.3 V, T = 25 °C	-3	—	3	%
		EM0 or EM1, Across operating temperature range	-18	—	22	%
		EM2 or EM3, Source mode, RANGESEL ₁ = RANGE0, AVDD=3.3 V, T = 25 °C	—	-2	—	%
		EM2 or EM3, Source mode, RANGESEL ₁ = RANGE1, AVDD=3.3 V, T = 25 °C	—	-1.7	—	%
		EM2 or EM3, Source mode, RANGESEL ₁ = RANGE2, AVDD=3.3 V, T = 25 °C	—	-0.8	—	%
		EM2 or EM3, Source mode, RANGESEL ₁ = RANGE3, AVDD=3.3 V, T = 25 °C	—	-0.5	—	%
		EM2 or EM3, Sink mode, RANGESEL ₁ = RANGE0, AVDD=3.3 V, T = 25 °C	—	-0.7	—	%
		EM2 or EM3, Sink mode, RANGESEL ₁ = RANGE1, AVDD=3.3 V, T = 25 °C	—	-0.6	—	%
		EM2 or EM3, Sink mode, RANGESEL ₁ = RANGE2, AVDD=3.3 V, T = 25 °C	—	-0.5	—	%
		EM2 or EM3, Sink mode, RANGESEL ₁ = RANGE3, AVDD=3.3 V, T = 25 °C	—	-0.5	—	%

Parameter	Symbol	Test Condition	Min	Typ	Max	Unit
Start up time	tIDAC_SU	Output within 1% of steady state value	—	5	—	µs
Settling time, (output settled within 1% of steady state value),	tIDAC_SETTLE	Range setting is changed	—	5	—	µs
		Step value is changed	—	1	—	µs
Current consumption ²	I _{IDAC}	EM0 or EM1 Source mode, excluding output current, Across operating temperature range	—	11	15	µA
		EM0 or EM1 Sink mode, excluding output current, Across operating temperature range	—	13	18	µA
		EM2 or EM3 Source mode, excluding output current, T = 25 °C	—	0.023	—	µA
		EM2 or EM3 Sink mode, excluding output current, T = 25 °C	—	0.041	—	µA
		EM2 or EM3 Source mode, excluding output current, T ≥ 85 °C	—	11	—	µA
		EM2 or EM3 Sink mode, excluding output current, T ≥ 85 °C	—	13	—	µA
Output voltage compliance in source mode, source current change relative to current sourced at 0 V	I _{COMP_SRC}	RANGESEL ₁ = RANGE0, output voltage = min(V _{IOVDD} , V _{AVDD2} -100 mV)	—	0.11	—	%
		RANGESEL ₁ = RANGE1, output voltage = min(V _{IOVDD} , V _{AVDD2} -100 mV)	—	0.06	—	%
		RANGESEL ₁ = RANGE2, output voltage = min(V _{IOVDD} , V _{AVDD2} -150 mV)	—	0.04	—	%
		RANGESEL ₁ = RANGE3, output voltage = min(V _{IOVDD} , V _{AVDD2} -250 mV)	—	0.03	—	%
Output voltage compliance in sink mode, sink current change relative to current sunk at IOVDD	I _{COMP_SINK}	RANGESEL ₁ = RANGE0, output voltage = 100 mV	—	0.12	—	%
		RANGESEL ₁ = RANGE1, output voltage = 100 mV	—	0.05	—	%
		RANGESEL ₁ = RANGE2, output voltage = 150 mV	—	0.04	—	%
		RANGESEL ₁ = RANGE3, output voltage = 250 mV	—	0.03	—	%

Note:

1. In IDAC_CURPROG register.
2. The IDAC is supplied by either AVDD, DVDD, or IOVDD based on the setting of ANASW in the EMU_PWRCTRL register and PWRSEL in the IDAC_CTRL register. Setting PWRSEL to 1 selects IOVDD. With PWRSEL cleared to 0, ANASW selects between AVDD (0) and DVDD (1).

4.1.17 Capacitive Sense (CSEN)

Table 4.25. Capacitive Sense (CSEN)

Parameter	Symbol	Test Condition	Min	Typ	Max	Unit
Single conversion time (1x accumulation)	tCNV	12-bit SAR Conversions	—	20.2	—	µs
		16-bit SAR Conversions	—	26.4	—	µs
		Delta Modulation Conversion (single comparison)	—	1.55	—	µs
Maximum external capacitive load	CEXTMAX	IREFPROG=7 (Gain = 1x), including routing parasitics	—	68	—	pF
		IREFPROG=0 (Gain = 10x), including routing parasitics	—	680	—	pF
Maximum external series impedance	REXTMAX		—	1	—	kΩ
Supply current, EM2 bonded conversions, WARMUP-MODE=NORMAL, WARMUPCNT=0	ICSEN_BOND	12-bit SAR conversions, 20 ms conversion rate, IREFPROG=7 (Gain = 1x), 10 channels bonded (total capacitance of 330 pF) ¹	—	326	—	nA
		Delta Modulation conversions, 20 ms conversion rate, IREFPROG=7 (Gain = 1x), 10 channels bonded (total capacitance of 330 pF) ¹	—	226	—	nA
		12-bit SAR conversions, 200 ms conversion rate, IREFPROG=7 (Gain = 1x), 10 channels bonded (total capacitance of 330 pF) ¹	—	33	—	nA
		Delta Modulation conversions, 200 ms conversion rate, IREFPROG=7 (Gain = 1x), 10 channels bonded (total capacitance of 330 pF) ¹	—	25	—	nA
Supply current, EM2 scan conversions, WARMUP-MODE=NORMAL, WARMUPCNT=0	ICSEN_EM2	12-bit SAR conversions, 20 ms scan rate, IREFPROG=0 (Gain = 10x), 8 samples per scan ¹	—	690	—	nA
		Delta Modulation conversions, 20 ms scan rate, 8 comparisons per sample (DMCR = 1, DMR = 2), IREFPROG=0 (Gain = 10x), 8 samples per scan ¹	—	515	—	nA
		12-bit SAR conversions, 200 ms scan rate, IREFPROG=0 (Gain = 10x), 8 samples per scan ¹	—	79	—	nA
		Delta Modulation conversions, 200 ms scan rate, 8 comparisons per sample (DMCR = 1, DMR = 2), IREFPROG=0 (Gain = 10x), 8 samples per scan ¹	—	57	—	nA

Parameter	Symbol	Test Condition	Min	Typ	Max	Unit
Supply current, continuous conversions, WARMUP-MODE=KEEP_CSEN_WARM	ICSEN_ACTIVE	SAR or Delta Modulation conversions of 33 pF capacitor, IRE-FPROG=0 (Gain = 10x), always on	—	90.5	—	μA
HFPERCLK supply current	ICSEN_HFPERCLK	Current contribution from HFPERCLK when clock to CSEN block is enabled.	—	2.25	—	μA/MHz

Note:

1. Current is specified with a total external capacitance of 33 pF per channel. Average current is dependent on how long the peripheral is actively sampling channels within the scan period, and scales with the number of samples acquired. Supply current for a specific application can be estimated by multiplying the current per sample by the total number of samples per period (total_current = single_sample_current * (number_of_channels * accumulation)).

4.1.18 Operational Amplifier (OPAMP)

Unless otherwise indicated, specified conditions are: Non-inverting input configuration, VDD = 3.3 V, DRIVESTRENGTH = 2, MAIN-OUTEN = 1, CLOAD = 75 pF with OUTSCALE = 0, or CLOAD = 37.5 pF with OUTSCALE = 1. Unit gain buffer and 3X-gain connection as specified in table footnotes^{1 2}.

Table 4.26. Operational Amplifier (OPAMP)

Parameter	Symbol	Test Condition	Min	Typ	Max	Unit
Supply voltage (from AVDD)	VOPA	HCMDIS = 0, Rail-to-rail input range	2	—	3.8	V
		HCMDIS = 1	1.62	—	3.8	V
Input voltage	VIN	HCMDIS = 0, Rail-to-rail input range	Vvss	—	VOPA	V
		HCMDIS = 1	Vvss	—	VOPA-1.2	V
Input impedance	RIN		100	—	—	MΩ
Output voltage	VOUT		Vvss	—	VOPA	V
Load capacitance ³	CLOAD	OUTSCALE = 0	—	—	75	pF
		OUTSCALE = 1	—	—	37.5	pF
Output impedance	ROUT	DRIVESTRENGTH = 2 or 3, 0.4 V ≤ VOUT ≤ VOPA - 0.4 V, -8 mA < IOUT < 8 mA, Buffer connection, Full supply range	—	0.25	—	Ω
		DRIVESTRENGTH = 0 or 1, 0.4 V ≤ VOUT ≤ VOPA - 0.4 V, -400 μA < IOUT < 400 μA, Buffer connection, Full supply range	—	0.6	—	Ω
		DRIVESTRENGTH = 2 or 3, 0.1 V ≤ VOUT ≤ VOPA - 0.1 V, -2 mA < IOUT < 2 mA, Buffer connection, Full supply range	—	0.4	—	Ω
		DRIVESTRENGTH = 0 or 1, 0.1 V ≤ VOUT ≤ VOPA - 0.1 V, -100 μA < IOUT < 100 μA, Buffer connection, Full supply range	—	1	—	Ω
Internal closed-loop gain	GCL	Buffer connection	0.99	1	1.01	-
		3x Gain connection	2.93	2.99	3.05	-
		16x Gain connection	15.07	15.7	16.33	-
Active current ⁴	IOPA	DRIVESTRENGTH = 3, OUTSCALE = 0	—	580	—	μA
		DRIVESTRENGTH = 2, OUTSCALE = 0	—	176	—	μA
		DRIVESTRENGTH = 1, OUTSCALE = 0	—	13	—	μA
		DRIVESTRENGTH = 0, OUTSCALE = 0	—	4.7	—	μA

Parameter	Symbol	Test Condition	Min	Typ	Max	Unit
Open-loop gain	GoL	DRIVESTRENGTH = 3	—	135	—	dB
		DRIVESTRENGTH = 2	—	137	—	dB
		DRIVESTRENGTH = 1	—	121	—	dB
		DRIVESTRENGTH = 0	—	109	—	dB
Loop unit-gain frequency ⁵	UGF	DRIVESTRENGTH = 3, Buffer connection	—	3.38	—	MHz
		DRIVESTRENGTH = 2, Buffer connection	—	0.9	—	MHz
		DRIVESTRENGTH = 1, Buffer connection	—	132	—	kHz
		DRIVESTRENGTH = 0, Buffer connection	—	34	—	kHz
		DRIVESTRENGTH = 3, 3x Gain connection	—	2.57	—	MHz
		DRIVESTRENGTH = 2, 3x Gain connection	—	0.71	—	MHz
		DRIVESTRENGTH = 1, 3x Gain connection	—	113	—	kHz
		DRIVESTRENGTH = 0, 3x Gain connection	—	28	—	kHz
Phase margin	PM	DRIVESTRENGTH = 3, Buffer connection	—	67	—	°
		DRIVESTRENGTH = 2, Buffer connection	—	69	—	°
		DRIVESTRENGTH = 1, Buffer connection	—	63	—	°
		DRIVESTRENGTH = 0, Buffer connection	—	68	—	°
Output voltage noise	NOUT	DRIVESTRENGTH = 3, Buffer connection, 10 Hz - 10 MHz	—	146	—	μVrms
		DRIVESTRENGTH = 2, Buffer connection, 10 Hz - 10 MHz	—	163	—	μVrms
		DRIVESTRENGTH = 1, Buffer connection, 10 Hz - 1 MHz	—	170	—	μVrms
		DRIVESTRENGTH = 0, Buffer connection, 10 Hz - 1 MHz	—	176	—	μVrms
		DRIVESTRENGTH = 3, 3x Gain connection, 10 Hz - 10 MHz	—	313	—	μVrms
		DRIVESTRENGTH = 2, 3x Gain connection, 10 Hz - 10 MHz	—	271	—	μVrms
		DRIVESTRENGTH = 1, 3x Gain connection, 10 Hz - 1 MHz	—	247	—	μVrms
		DRIVESTRENGTH = 0, 3x Gain connection, 10 Hz - 1 MHz	—	245	—	μVrms

Parameter	Symbol	Test Condition	Min	Typ	Max	Unit
Slew rates	SR	DRIVESTRENGTH = 3, INCBW=17	—	4.7	—	V/μs
		DRIVESTRENGTH = 3, INCBW=0	—	1.5	—	V/μs
		DRIVESTRENGTH = 2, INCBW=17	—	1.27	—	V/μs
		DRIVESTRENGTH = 2, INCBW=0	—	0.42	—	V/μs
		DRIVESTRENGTH = 1, INCBW=17	—	0.17	—	V/μs
		DRIVESTRENGTH = 1, INCBW=0	—	0.058	—	V/μs
		DRIVESTRENGTH = 0, INCBW=17	—	0.044	—	V/μs
		DRIVESTRENGTH = 0, INCBW=0	—	0.015	—	V/μs
Startup times	TSTART	DRIVESTRENGTH = 2	—	—	12	μs
Input offset voltage	Vosi	DRIVESTRENGTH = 2 or 3, T = 25 °C	-2	—	2	mV
		DRIVESTRENGTH = 1 or 0, T = 25 °C	-2	—	2	mV
		DRIVESTRENGTH = 2 or 3, across operating temperature range	-12	—	12	mV
		DRIVESTRENGTH = 1 or 0, across operating temperature range	-45	—	30	mV
DC power supply rejection ratios	PSRRDC	Input referred	—	70	—	dB
DC common-mode rejection ratios	CMRRDC	Input referred	—	70	—	dB
Total harmonic distortion	THDOPA	DRIVESTRENGTH = 2, 3x Gain connection, 1 kHz, VOUT = 0.1 V to VOPA - 0.1 V	—	90	—	dB
		DRIVESTRENGTH = 0, 3x Gain connection, 0.1 kHz, VOUT = 0.1 V to VOPA - 0.1 V	—	90	—	dB

Parameter	Symbol	Test Condition	Min	Typ	Max	Unit
Note:						
1. Specified configuration for Unit gain buffer configuration is: INCBW = 0, HCMDIS = 0, RESINSEL = DISABLE. V _{INPUT} = 0.5 V, V _{OUTPUT} = 0.5 V.						
2. Specified configuration for 3X-Gain configuration is: INCBW = 1, HCMDIS = 1, RESINSEL = VSS, V _{INPUT} = 0.5 V, V _{OUTPUT} = 1.5 V. Nominal voltage gain is 3.						
3. If the maximum C _{LOAD} is exceeded, an isolation resistor is required for stability. See AN0038 for more information.						
4. Current into the load resistor is excluded. When the OPAMP is connected with closed-loop gain > 1, there will be extra current to drive the resistor feedback network. The internal resistor feedback network has total resistance of 143.5 kOhm, which will cause another ~10 μA current when the OPAMP drives 1.5 V between output and ground.						
5. In unit gain connection, UGF is the gain-bandwidth product of the OPAMP. In 3x Gain connection, UGF is the gain-bandwidth product of the OPAMP and 1/3 attenuation of the feedback network.						
6. Step between 0.2V and V _{OPA} -0.2V, 10%-90% rising/falling range.						
7. When INCBW is set to 1 the OPAMP bandwidth is increased. This is allowed only when the non-inverting close-loop gain is ≥ 3, or the OPAMP may not be stable.						
8. From enable to output settled. In sample-and-off mode, RC network after OPAMP will contribute extra delay. Settling error < 1mV.						
9. When HCMDIS=1 and input common mode transitions the region from V _{OPA} -1.4V to V _{OPA} -1V, input offset will change. PSRR and CMRR specifications do not apply to this transition region.						

4.1.19 Pulse Counter (PCNT)

Table 4.27. Pulse Counter (PCNT)

Parameter	Symbol	Test Condition	Min	Typ	Max	Unit
Input frequency	F _{IN}	Asynchronous Single and Quadrature Modes	—	—	10	MHz
		Sampled Modes with Debounce filter set to 0.	—	—	8	kHz

4.1.20 Analog Port (APORT)

Table 4.28. Analog Port (APORT)

Parameter	Symbol	Test Condition	Min	Typ	Max	Unit
Supply current ^{1 2}	I _{APORT}	Operation in EM0/EM1	—	7	—	μA
		Operation in EM2/EM3	—	63	—	nA

Note:

- Supply current increase that occurs when an analog peripheral requests access to APORT. This current is not included in reported peripheral currents. Additional peripherals requesting access to APORT do not incur further current.
- Specified current is for continuous APORT operation. In applications where the APORT is not requested continuously (e.g. periodic ACMP requests from LESENSE in EM2), the average current requirements can be estimated by multiplying the duty cycle of the requests by the specified continuous current number.

4.1.21 I2C

4.1.21.1 I2C Standard-mode (Sm)¹Table 4.29. I2C Standard-mode (Sm)¹

Parameter	Symbol	Test Condition	Min	Typ	Max	Unit
SCL clock frequency ²	fSCL		0	—	100	kHz
SCL clock low time	tLOW		4.7	—	—	μs
SCL clock high time	tHIGH		4	—	—	μs
SDA set-up time	tSU_DAT		250	—	—	ns
SDA hold time ³	tHD_DAT		100	—	3450	ns
Repeated START condition set-up time	tSU_STA		4.7	—	—	μs
(Repeated) START condition hold time	tHD_STA		4	—	—	μs
STOP condition set-up time	tSU_STO		4	—	—	μs
Bus free time between a STOP and START condition	tBUF		4.7	—	—	μs

Note:

1. For CLHR set to 0 in the I2Cn_CTRL register.
2. For the minimum HFPERCLK frequency required in Standard-mode, refer to the I2C chapter in the reference manual.
3. The maximum SDA hold time (tHD_DAT) needs to be met only when the device does not stretch the low time of SCL (tLOW).

4.1.21.2 I2C Fast-mode (Fm)¹Table 4.30. I2C Fast-mode (Fm)¹

Parameter	Symbol	Test Condition	Min	Typ	Max	Unit
SCL clock frequency ²	fSCL		0	—	400	kHz
SCL clock low time	t _{LOW}		1.3	—	—	μs
SCL clock high time	t _{HIGH}		0.6	—	—	μs
SDA set-up time	t _{SU_DAT}		100	—	—	ns
SDA hold time ³	t _{HD_DAT}		100	—	900	ns
Repeated START condition set-up time	t _{SU_STA}		0.6	—	—	μs
(Repeated) START condition hold time	t _{HD_STA}		0.6	—	—	μs
STOP condition set-up time	t _{SU_STO}		0.6	—	—	μs
Bus free time between a STOP and START condition	t _{BUF}		1.3	—	—	μs

Note:

- 1.For CLHR set to 1 in the I2Cn_CTRL register.
- 2.For the minimum HFPERCLK frequency required in Fast-mode, refer to the I2C chapter in the reference manual.
- 3.The maximum SDA hold time (t_{HD,DAT}) needs to be met only when the device does not stretch the low time of SCL (t_{LOW}).

4.1.21.3 I2C Fast-mode Plus (Fm+)1

Table 4.31. I2C Fast-mode Plus (Fm+)1

Parameter	Symbol	Test Condition	Min	Typ	Max	Unit
SCL clock frequency ²	fSCL		0	—	1000	kHz
SCL clock low time	tLOW		0.5	—	—	μs
SCL clock high time	tHIGH		0.26	—	—	μs
SDA set-up time	tSU_DAT		50	—	—	ns
SDA hold time	tHD_DAT		100	—	—	ns
Repeated START condition set-up time	tSU_STA		0.26	—	—	μs
(Repeated) START condition hold time	tHD_STA		0.26	—	—	μs
STOP condition set-up time	tSU_STO		0.26	—	—	μs
Bus free time between a STOP and START condition	tBUF		0.5	—	—	μs

Note:

- 1.For CLHR set to 0 or 1 in the I2Cn_CTRL register.
- 2.For the minimum HPPERCLK frequency required in Fast-mode Plus, refer to the I2C chapter in the reference manual.

4.1.22 USART SPI Master Timing

Table 4.32. SPI Master Timing

Parameter	Symbol	Test Condition	Min	Typ	Max	Unit
SCLK period 1 2 3	tSCLK		2 * tHFPERCLK	—	—	ns
CS to MOSI 1 2	tCS_MO		-12.5	—	14	ns
SCLK to MOSI 1 2	tSCLK_MO		-8.5	—	10.5	ns
MISO setup time 1 2	tSU_MI	IOVDD = 1.62 V	90	—	—	ns
		IOVDD = 3.0 V	42	—	—	ns
MISO hold time 1 2	tH_MI		-9	—	—	ns

Note:

1. Applies for both CLKPHA = 0 and CLKPHA = 1 (figure only shows CLKPHA = 0).
2. Measurement done with 8 pF output loading at 10% and 90% of VDD (figure shows 50% of VDD).
3. tHFPERCLK is one period of the selected HFPERCLK.

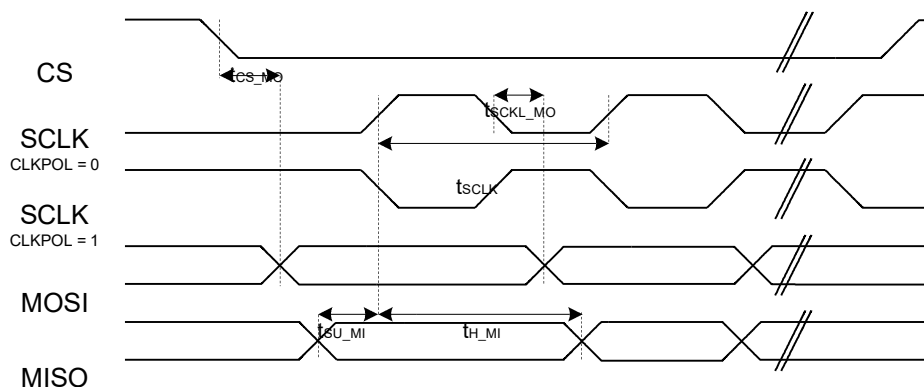

Figure 4.1. SPI Master Timing Diagram

4.1.23 USART SPI Slave Timing

Table 4.33. SPI Slave Timing

Parameter	Symbol	Test Condition	Min	Typ	Max	Unit
SCLK period 1 2 3	tSCLK		6 * tHFPERCLK	—	—	ns
SCLK high time1 2 3	tSCLK_HI		2.5 * tHFPERCLK	—	—	ns
SCLK low time1 2 3	tSCLK_LO		2.5 * tHFPERCLK	—	—	ns
CS active to MISO 1 2	tCS_ACT_MI		4	—	70	ns
CS disable to MISO 1 2	tCS_DIS_MI		4	—	50	ns
MOSI setup time 1 2	tSU_MO		12.5	—	—	ns
MOSI hold time 1 2 3	tH_MO		13	—	—	ns
SCLK to MISO 1 2 3	tSCLK_MI		6 + 1.5 * tHFPERCLK	—	45 + 2.5 * tHFPERCLK	ns

Note:

- 1.Applies for both CLKPHA = 0 and CLKPHA = 1 (figure only shows CLKPHA = 0).
- 2.Measurement done with 8 pF output loading at 10% and 90% of VDD (figure shows 50% of VDD).
- 3.tHFPERCLK is one period of the selected HFPERCLK.

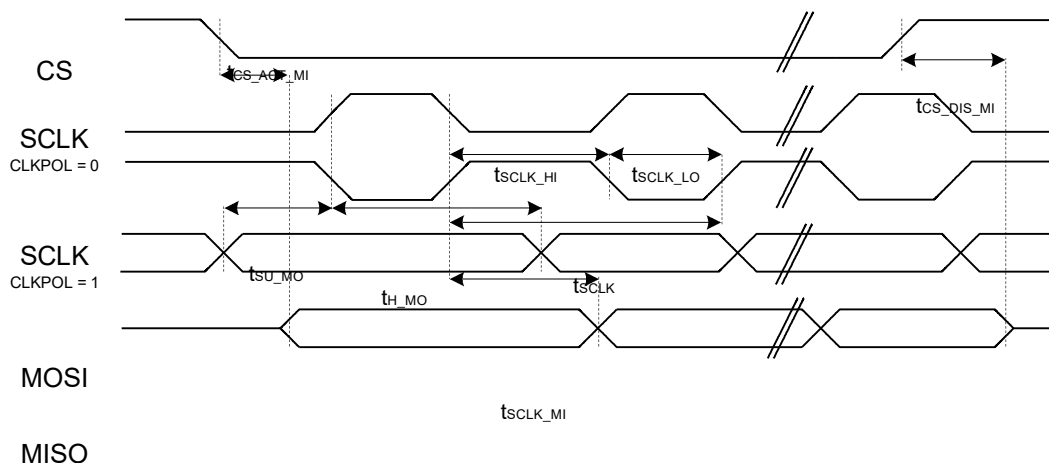

Figure 4.2. SPI Slave Timing Diagram

4.2 Typical Performance Curves

Typical performance curves indicate typical characterized performance under the stated conditions.

4.2.1 Zwave Radio

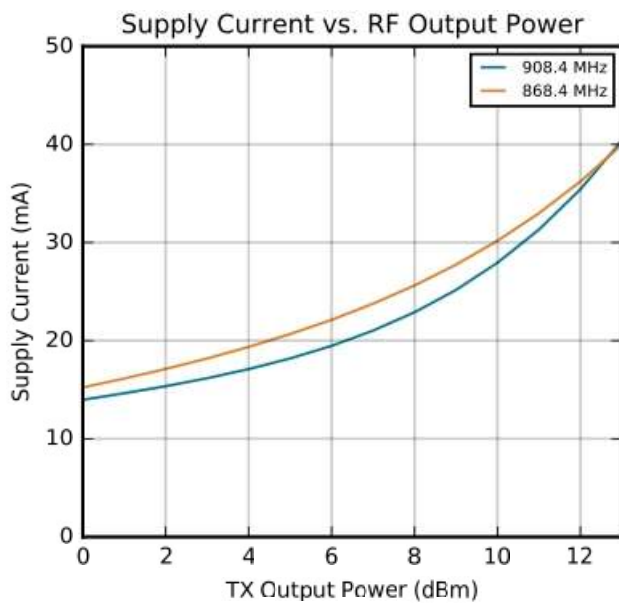

Figure 4.3. RF Transmitter Output Power

RF transmitter output power measured based on reference design BRD4200 at the output of the ZGM130S device.

5. Typical Connection Diagrams

5.1 Typical ZGM130S Connections

Typical connections for the ZGM130S module are shown in [Figure 5.1 Typical Power Connections for ZGM130S](#) on page 60 and [Figure 5.2 Typical RF Connections for ZGM130S](#) on page 60.

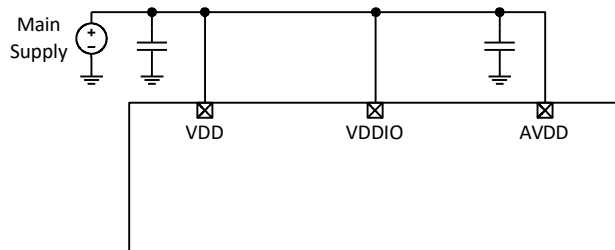

Figure 5.1. Typical Power Connections for ZGM130S

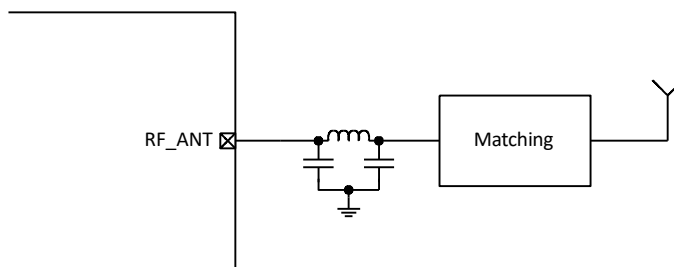

Figure 5.2. Typical RF Connections for ZGM130S

A programming interface is mandatory if In-System Programming of a Z-Wave 700 device is required, i.e., programming a new/erased chip while soldered onto the product PCB. To design in a footprint for the Mini Simplicity header, Silicon Labs recommends using a small 10-pin 1.27 mm SMD header for both programming and debugging of chips from the Silicon Labs Gecko family.

6. Pin Definitions

6.1 ZGM130S Device Pinout

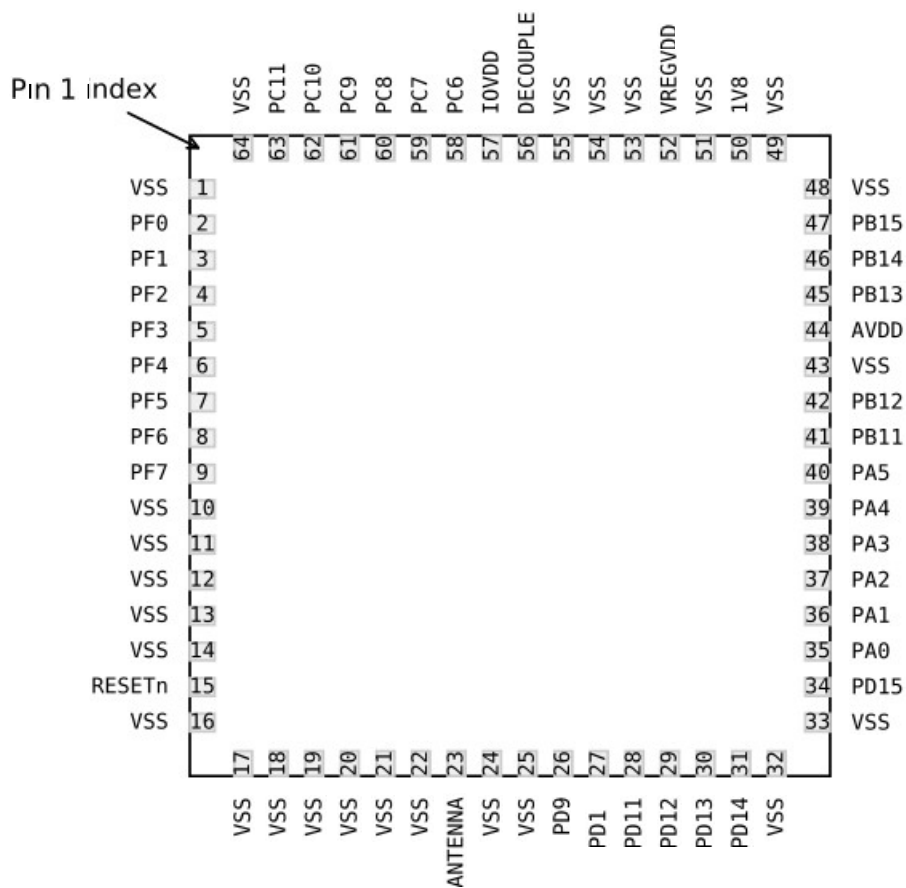

Figure 6.1. ZGM130S Device Pinout

The following table provides package pin connections and general descriptions of pin functionality. For detailed information on the supported features for each GPIO pin, see [6.2 GPIO Functionality Table](#) or [6.3 Alternate Functionality Overview](#).

Table 6.1. ZGM130S Device Pinout

Pin Name	Pin(s)	Description	Pin Name	Pin(s)	Description
VSS	1 10 11 12 13 14 16 17 18 19 20 21 22 24 25 32 33 43 48 49 51 53 54 55 64	Ground	PF0	2	GPIO (5V)
PF1	3	GPIO (5V)	PF2	4	GPIO (5V)
PF3	5	GPIO (5V)	PF4	6	GPIO (5V)
PF5	7	GPIO (5V)	PF6	8	GPIO (5V)
PF7	9	GPIO (5V)	RESETn	15	Reset input, active low. This pin is internally pulled up to AVDD. To apply an external reset source to this pin, it is required to only drive this pin low during reset, and let the internal pull-up ensure that reset is released.
ANTENNA	23	50 Ohm RF IO.	PD9	26	GPIO (5V)
PD10	27	GPIO (5V)	PD11	28	GPIO (5V)
PD12	29	GPIO (5V)	PD13	30	GPIO
PD14	31	GPIO	PD15	34	GPIO
PA0	35	GPIO	PA1	36	GPIO
PA2	37	GPIO	PA3	38	GPIO
PA4	39	GPIO	PA5	40	GPIO (5V)
PB11	41	GPIO	PB12	42	GPIO
AVDD	44	Analog power supply.	PB13	45	GPIO
PB14	46	GPIO	PB15	47	GPIO
1V8	50	1.8V output of the internal DC-DC converter. Internally decoupled - do not add external decoupling.	VREGVDD	52	Voltage regulator VDD input

Pin Name	Pin(s)	Description	Pin Name	Pin(s)	Description
DECOUPLE	56	N.C. This pin is the decouple output for an on-chip voltage regulator. This pin is internally decoupled, and should be left unconnected on the PCB.	IOVDD	57	Digital IO power supply.
PC6	58	GPIO (5V)	PC7	59	GPIO (5V)
PC8	60	GPIO (5V)	PC9	61	GPIO (5V)
PC10	62	GPIO (5V)	PC11	63	GPIO (5V)
Note: 1.GPIO with 5V tolerance are indicated by (5V).					

6.2 GPIO Functionality Table

A wide selection of alternate functionality is available for multiplexing to various pins. The following table shows the name of each GPIO pin, followed by the functionality available on that pin. Refer to [6.3 Alternate Functionality Overview](#) for a list of GPIO locations available for each function.

Table 6.2. GPIO Functionality Table

GPIO Name	Pin Alternate Functionality / Description				
	Analog	Timers	Communication	Radio	Other
PA0		TIM0_CC0 #0	US0_TX #0		
		TIM0_CC1 #31	US0_RX #31		
		TIM0_CC2 #30	US0_CLK #30		
		TIM0_CDTI0 #29	US0_CS #29		
		TIM0_CDTI1 #28	US0_CTS #28		CMU_CLK1 #0
		TIM0_CDTI2 #27	US0_RTS #27	FRC_DCLK #0	PRS_CH6 #0
	BUSDY	TIM1_CC0 #0	US1_TX #0	FRC_DOUT #31	PRS_CH7 #10
	BUSCX	TIM1_CC1 #31	US1_RX #31	FRC_DFRAME #30	PRS_CH8 #9
	ADC0_EXTN	TIM1_CC2 #30	US1_CLK #30	MODEM_DCLK #0	PRS_CH9 #8
		TIM1_CC3 #29	US1_CS #29	MODEM_DIN #31	ACMP0_O #0
		WTIM0_CC0 #0	US1_CTS #28	MODEM_DOUT #30	ACMP1_O #0
		LETIM0_OUT0 #0	US1_RTS #27		LES_CH8
		LETIM0_OUT1 #31	LEU0_TX #0		
		PCNT0_S0IN #0	LEU0_RX #31		
		PCNT0_S1IN #31	I2C0_SDA #0		
			I2C0_SCL #31		

GPIO Name	Pin Alternate Functionality / Description				
	Analog	Timers	Communication	Radio	Other
PA1	BUSCY BUSDX ADC0_EXTP VDAC0_EXT	TIM0_CC0#1 TIM0_CC1#0 TIM0_CC2 #31 TIM0_CDTI0#30 TIM0_CDTI1#29 TIM0_CDTI2 #28 TIM1_CC0#1 TIM1_CC1#0 TIM1_CC2#31 TIM1_CC3#30 WTIM0_CC0 #1 LETIM0_OUT0#1 LETIM0_OUT1#0 PCNT0_S0IN#1 PCNT0_S1IN #0	US0_TX #1 US0_RX #0 US0_CLK#31 US0_CS#30 US0_CTS#29 US0_RTS #28 US1_TX#1 US1_RX #0 US1_CLK#31 US1_CS#30 US1_CTS #29 US1_RTS #28 LEU0_TX#1 LEU0_RX#0 I2C0_SDA#1	FRC_DCLK#1 FRC_DOUT #0 FRC_DFRAME #31 MODEM_DCLK #1 MODEM_DIN #0 MODEM_DOUT #31	CMU_CLK0#0 PRS_CH6#1 PRS_CH7#0 PRS_CH8#10 PRS_CH9#9 ACMP0_O #1 ACMP1_O #1 LES_CH9
PA2	VDAC0_OUT1ALT / OPA1_OUTALT #1 BUSDY BUSCX OPA0_P	TIM0_CC0#2 TIM0_CC1#1 TIM0_CC2 #0 TIM0_CDTI0#31 TIM0_CDTI1#30 TIM0_CDTI2 #29 TIM1_CC0#2 TIM1_CC1#1 TIM1_CC2#0 TIM1_CC3#31 WTIM0_CC0 #2 WTIM0_CC1 #0 LETIM0_OUT0#2 LETIM0_OUT1#1 PCNT0_S0IN#2 PCNT0_S1IN #1	US0_TX #2 US0_RX#1 US0_CLK#0 US0_CS#31 US0_CTS#30 US0_RTS #29 US1_TX#2 US1_RX#1 US1_CLK#0 US1_CS#31 US1_CTS#30 US1_RTS #29 LEU0_TX#2 LEU0_RX#1 I2C0_SDA#2 I2C0_SCL #1	FRC_DCLK #2 FRC_DOUT#1 FRC_DFRAME#0 MODEM_DCLK #2 MODEM_DIN #1 MODEM_DOUT #0	PRS_CH6#2 PRS_CH7#1 PRS_CH8#0 PRS_CH9#10 ACMP0_O #2 ACMP1_O #2 LES_CH10

GPIO Name	Pin Alternate Functionality / Description				
	Analog	Timers	Communication	Radio	Other
PA3	BUSCY BUSDX VDAC0_OUT0 / OPA0_OUT	TIM0_CC0#3	US0_TX#3		
		TIM0_CC1#2	US0_RX#2		
		TIM0_CC2#1	US0_CLK#1		
		TIM0_CDTI0#0	US0_CS#0		
		TIM0_CDTI1#31	US0_CTS#31		PRS_CH6#3
		TIM0_CDTI2#30	US0_RTS#30	FRC_DCLK#3	PRS_CH7#2
		TIM1_CC0#3	US1_TX#3	FRC_DOUT#2	PRS_CH8#1
		TIM1_CC1#2	US1_RX#2	FRC_DFRAME#1	PRS_CH9#0
		TIM1_CC2#1	US1_CLK#1	MODEM_DCLK#3	ACMP0_O#3
		TIM1_CC3#0	US1_CS#0	MODEM_DIN#2	ACMP1_O#3
		WTIM0_CC0#3	US1_CTS#31	MODEM_DOUT#1	LES_CH11
		WTIM0_CC1#1	US1_RTS#30		GPIO_EM4WU8
		LETIM0_OUT0#3	LEU0_TX#3		
		LETIM0_OUT1#2	LEU0_RX#2		
PCNT0_S0IN#3	I2C0_SDA#3				
PCNT0_S1IN#2	I2C0_SCL#2				
PA4	VDAC0_OUT1ALT / OPA1_OUTALT#2 BUSDY BUSCX OPA0_N	TIM0_CC0#4	US0_TX#4		
		TIM0_CC1#3	US0_RX#3		
		TIM0_CC2#2	US0_CLK#2		
		TIM0_CDTI0#1	US0_CS#1		
		TIM0_CDTI1#0	US0_CTS#0		
		TIM0_CDTI2#31	US0_RTS#31	FRC_DCLK#4	PRS_CH6#4
		TIM1_CC0#4	US1_TX#4	FRC_DOUT#3	PRS_CH7#3
		TIM1_CC1#3	US1_RX#3	FRC_DFRAME#2	PRS_CH8#2
		TIM1_CC2#2	US1_CLK#2	MODEM_DCLK#4	PRS_CH9#1
		TIM1_CC3#1	US1_CS#1	MODEM_DIN#3	ACMP0_O#4
		WTIM0_CC0#4	US1_CTS#0	MODEM_DOUT#2	ACMP1_O#4
		WTIM0_CC1#2	US1_RTS#31		LES_CH12
		WTIM0_CC2#0	LEU0_TX#4		
		LETIM0_OUT0#4	LEU0_RX#3		
		LETIM0_OUT1#3	I2C0_SDA#4		
		PCNT0_S0IN#4	I2C0_SCL#3		
		PCNT0_S1IN#3			

GPIO Name	Pin Alternate Functionality / Description					
	Analog	Timers	Communication	Radio	Other	
PA5	VDAC0_OUT0ALT / OPA0_OUTALT #0 BUSCY BUSDX		US0_TX#5			
				US0_RX#4		
				US0_CLK#3		
			TIM0_CC0#5	US0_CS#2		
			TIM0_CC1#4	US0_CTS#1		
			TIM0_CC2#3	US0_RTS#0		
			TIM0_CDTI0#2	US1_TX#5		
			TIM0_CDTI1#1	US1_RX#4		CMU_CLKI0#4
			TIM0_CDTI2#0	US1_CLK#3	FRC_DCLK#5	PRS_CH6#5
			TIM1_CC0#5	US1_CS#2	FRC_DOUT#4	PRS_CH7#4
			TIM1_CC1#4	US1_CTS#1	FRC_DFRAME#3	PRS_CH8#3
			TIM1_CC2#3	US1_RTS#0	MODEM_DCLK#5	PRS_CH9#2
			TIM1_CC3#2	US2_TX#0	MODEM_DIN#4	ACMP0_O#5
			WTIM0_CC0#5	US2_RX#31	MODEM_DOUT#3	ACMP1_O#5
			WTIM0_CC1#3	US2_CLK#30		LES_CH13
			WTIM0_CC2#1	US2_CS#29		ETM_TCLK#1
			LETIM0_OUT0#5	US2_CTS#28		
			LETIM0_OUT1#4	US2_RTS#27		
			PCNT0_S0IN#5	LEU0_TX#5		
			PCNT0_S1IN#4	LEU0_RX#4		
				I2C0_SDA#5		
				I2C0_SCL#4		

GPIO Name	Pin Alternate Functionality / Description				
	Analog	Timers	Communication	Radio	Other
PB11		TIM0_CC0 #6			
		TIM0_CC1 #5			
		TIM0_CC2 #4	US0_TX #6		
		TIM0_CDTI0 #3	US0_RX #5		
		TIM0_CDTI1 #2	US0_CLK #4		
		TIM0_CDTI2 #1	US0_CS #3		
		TIM1_CC0 #6	US0_CTS #2		
		TIM1_CC1 #5	US0_RTS #1	FRC_DCLK #6	PRS_CH6 #6
	BUSCY	TIM1_CC2 #4	US1_TX #6	FRC_DOUT #5	PRS_CH7 #5
	BUSDY	TIM1_CC3 #3	US1_RX #5	FRC_DFRAME #4	PRS_CH8 #4
	BUSDZ	WTIM0_CC0 #15	US1_CLK #4	MODEM_DCLK #6	PRS_CH9 #3
	OPA2_P	WTIM0_CC1 #13	US1_CS #3	MODEM_DIN #5	ACMP0_O #6
		WTIM0_CC2 #11	US1_CTS #2	MODEM_DOUT #4	ACMP1_O #6
		WTIM0_CDTI0 #7	US1_RTS #1		
		WTIM0_CDTI1 #5	LEU0_TX #6		
		WTIM0_CDTI2 #3	LEU0_RX #5		
		LETIM0_OUT0 #6	I2C0_SDA #6		
		LETIM0_OUT1 #5	I2C0_SCL #5		
		PCNT0_S0IN #6			
		PCNT0_S1IN #5			

GPIO Name	Pin Alternate Functionality / Description				
	Analog	Timers	Communication	Radio	Other
PB12		TIM0_CC0 #7			
		TIM0_CC1 #6			
		TIM0_CC2 #5	US0_TX #7		
		TIM0_CDTI0 #4	US0_RX #6		
		TIM0_CDTI1 #3	US0_CLK #5		
		TIM0_CDTI2 #2	US0_CS #4		
		TIM1_CC0 #7	US0_CTS #3		
		TIM1_CC1 #6	US0_RTS #2	FRC_DCLK #7	PRS_CH6 #7
	BUSDY	TIM1_CC2 #5	US1_TX #7	FRC_DOUT #6	PRS_CH7 #6
	BUSCX	TIM1_CC3 #4	US1_RX #6	FRC_DFRAME #5	PRS_CH8 #5
	OPA2_OUT	WTIM0_CC0 #16	US1_CLK #5	MODEM_DCLK #7	PRS_CH9 #4
		WTIM0_CC1 #14	US1_CS #4	MODEM_DIN #6	ACMP0_O #7
		WTIM0_CC2 #12	US1_CTS #3	MODEM_DOUT #5	ACMP1_O #7
		WTIM0_CDTI0 #8	US1_RTS #2		
		WTIM0_CDTI1 #6	LEU0_TX #7		
		WTIM0_CDTI2 #4	LEU0_RX #6		
		LETIM0_OUT0 #7	I2C0_SDA #7		
		LETIM0_OUT1 #6	I2C0_SCL #6		
		PCNT0_S0IN #7			
		PCNT0_S1IN #6			

GPIO Name	Pin Alternate Functionality / Description				
	Analog	Timers	Communication	Radio	Other
PB13	BUSCY BUSDX OPA2_N	TIM0_CC0 #8			
		TIM0_CC1 #7			
		TIM0_CC2 #6	US0_TX #8		
		TIM0_CDTI0 #5	US0_RX #7		
		TIM0_CDTI1 #4	US0_CLK #6		
		TIM0_CDTI2 #3	US0_CS #5		
		TIM1_CC0 #8	US0_CTS #4		
		TIM1_CC1 #7	US0_RTS #3	FRC_DCLK #8	
		TIM1_CC2 #6	US1_TX #8	FRC_DOUT #7	
		TIM1_CC3 #5	US1_RX #7	FRC_DFRAME #6	
		WTIM0_CC0 #17	US1_CLK #6	MODEM_DCLK #8	
		WTIM0_CC1 #15	US1_CS #5	MODEM_DIN #7	
		WTIM0_CC2 #13	US1_CTS #4	MODEM_DOUT #6	
		WTIM0_CDTI0 #9	US1_RTS #3		
		WTIM0_CDTI1 #7	LEU0_TX #8		
		WTIM0_CDTI2 #5	LEU0_RX #7		
		LETIM0_OUT0 #8	I2C0_SDA #8		
		LETIM0_OUT1 #7	I2C0_SCL #7		
		PCNT0_S0IN #8			
		PCNT0_S1IN #7			

GPIO Name	Pin Alternate Functionality / Description				
	Analog	Timers	Communication	Radio	Other
PB14	BUSDY BUSCX	TIM0_CC0 #9			
		TIM0_CC1 #8			
		TIM0_CC2 #7	US0_TX #9		
		TIM0_CDTI0 #6	US0_RX #8		
		TIM0_CDTI1 #5	US0_CLK #7		
		TIM0_CDTI2 #4	US0_CS #6		
		TIM1_CC0 #9	US0_CTS #5		
		TIM1_CC1 #8	US0_RTS #4	FRC_DCLK #9	CMU_CLK1 #1
		TIM1_CC2 #7	US1_TX #9	FRC_DOUT #8	PRS_CH6 #9
		TIM1_CC3 #6	US1_RX #8	FRC_DFRAME #7	PRS_CH7 #8
		WTIM0_CC0 #18	US1_CLK #7	MODEM_DCLK #9	PRS_CH8 #7
		WTIM0_CC1 #16	US1_CS #6	MODEM_DIN #8	PRS_CH9 #6
		WTIM0_CC2 #14	US1_CTS #5	MODEM_DOUT #7	ACMP0_O #9
		WTIM0_CDTI0 #10	US1_RTS #4		ACMP1_O #9
		WTIM0_CDTI1 #8	LEU0_TX #9		
		WTIM0_CDTI2 #6	LEU0_RX #8		
		LETIM0_OUT0 #9	I2C0_SDA #9		
		LETIM0_OUT1 #8	I2C0_SCL #8		
		PCNT0_S0IN #9			
		PCNT0_S1IN #8			

GPIO Name	Pin Alternate Functionality / Description				
	Analog	Timers	Communication	Radio	Other
PB15	BUSCY BUSDX	TIM0_CC0#10			
		TIM0_CC1#9			
		TIM0_CC2 #8	US0_TX#10		
		TIM0_CDT10#7	US0_RX#9		
		TIM0_CDT11#6	US0_CLK#8		
		TIM0_CDT12#5	US0_CS#7		
		TIM1_CC0#10	US0_CTS#6		
		TIM1_CC1#9	US0_RTS#5	FRC_DCLK#10	CMU_CLK0#1
		TIM1_CC2#8	US1_TX#10	FRC_DOUT #9	PRS_CH6#10
		TIM1_CC3 #7	US1_RX#9	FRC_DFRAME #8	PRS_CH7#9
		WTIM0_CC0#19	US1_CLK#8	MODEM_DCLK #10	PRS_CH8#8
		WTIM0_CC1#17	US1_CS#7	MODEM_DIN #9	PRS_CH9 #7
		WTIM0_CC2 #15	US1_CTS#6	MODEM_DOUT #8	ACMP0_O#10
		WTIM0_CDT10#11	US1_RTS#5		ACMP1_O #10
		WTIM0_CDT11#9	LEU0_TX#10		
		WTIM0_CDT12#7	LEU0_RX #9		
		LETIM0_OUT0 #10	I2C0_SDA#10		
		LETIM0_OUT1#9	I2C0_SCL #9		
		PCNT0_S0IN#10			

GPIO Name	Pin Alternate Functionality / Description				
	Analog	Timers	Communication	Radio	Other
PC6	BUSBY BUSAX	TIM0_CC0#11			
		TIM0_CC1#10			
		TIM0_CC2 #9	US0_TX#11		
		TIM0_CDTI0#8	US0_RX#10		
		TIM0_CDTI1#7	US0_CLK#9		
		TIM0_CDTI2#6	US0_CS #8		
		TIM1_CC0#11	US0_CTS#7		
		TIM1_CC1#10	US0_RTS#6	FRC_DCLK#11	CMU_CLK0#2
		TIM1_CC2#9	US1_TX#11	FRC_DOUT #10	CMU_CLKI0 #2
		TIM1_CC3 #8	US1_RX#10	FRC_DFRAME #9	PRS_CH0#8
		WTIM0_CC0#26	US1_CLK#9	MODEM_DCLK#11	PRS_CH9#11
		WTIM0_CC1#24	US1_CS #8	MODEM_DIN#10	PRS_CH10#0
		WTIM0_CC2 #22	US1_CTS#7	MODEM_DOUT #9	PRS_CH11#5
		WTIM0_CDTI0#18	US1_RTS#6		ACMP0_O#11
		WTIM0_CDTI1#16	LEU0_TX#11		ACMP1_O#11
		WTIM0_CDTI2#14	LEU0_RX#10		ETM_TCLK #3
		LETIM0_OUT0#11	I2C0_SDA#11		
		LETIM0_OUT1#10	I2C0_SCL #10		
		PCNT0_S0IN#11			
		PCNT0_S1IN #10			

GPIO Name	Pin Alternate Functionality / Description				
	Analog	Timers	Communication	Radio	Other
PC7	BUSAY BUSBX	TIM0_CC0#12			
		TIM0_CC1#11			
		TIM0_CC2#10	US0_TX#12		
		TIM0_CDTI0#9	US0_RX#11		
		TIM0_CDTI1#8	US0_CLK #10		
		TIM0_CDTI2#7	US0_CS#9		
		TIM1_CC0#12	US0_CTS#8		CMU_CLK1#2
		TIM1_CC1#11	US0_RTS#7	FRC_DCLK#12	PRS_CH0#9
		TIM1_CC2#10	US1_TX#12	FRC_DOUT #11	PRS_CH9#12
		TIM1_CC3 #9	US1_RX#11	FRC_DFRAME#10	PRS_CH10#1
		WTIM0_CC0#27	US1_CLK #10	MODEM_DCLK #12	PRS_CH11#0
		WTIM0_CC1#25	US1_CS#9	MODEM_DIN #11	ACMP0_O
		WTIM0_CC2 #23	US1_CTS#8	MODEM_DOUT #10	#12
		WTIM0_CDTI0#19	US1_RTS#7		ACMP1_O
		WTIM0_CDTI1#17	LEU0_TX#12		#12
		WTIM0_CDTI2#15	LEU0_RX#11		ETM_TD0
		LETIM0_OUT0#12	I2C0_SDA#12		
		LETIM0_OUT1#11	I2C0_SCL #11		
		PCNT0_S0IN#12			
		PCNT0_S1IN #11			

GPIO Name	Pin Alternate Functionality / Description				
	Analog	Timers	Communication	Radio	Other
PC8	BUSBY BUSAX	TIM0_CC0#13			
		TIM0_CC1#12			
		TIM0_CC2 #11	US0_TX#13		
		TIM0_CDTI0#10	US0_RX#12		
		TIM0_CDTI1#9	US0_CLK#11		
		TIM0_CDTI2#8	US0_CS#10		
		TIM1_CC0#13	US0_CTS#9		
		TIM1_CC1#12	US0_RTS#8	FRC_DCLK#13	PRS_CH0#10
		TIM1_CC2#11	US1_TX#13	FRC_DOUT #12	PRS_CH9#13
		TIM1_CC3 #10	US1_RX#12	FRC_DFRAME#11	PRS_CH10#2
		WTIM0_CC0#28	US1_CLK#11	MODEM_DCLK #13	PRS_CH11#1
		WTIM0_CC1#26	US1_CS#10	MODEM_DIN #12	ACMP0_O#13
		WTIM0_CC2 #24	US1_CTS#9	MODEM_DOUT #11	ACMP1_O #13
		WTIM0_CDTI0#20	US1_RTS#8		ETM_TD1
		WTIM0_CDTI1 #18	LEU0_TX#13		
		WTIM0_CDTI2#16	LEU0_RX#12		
		LETIM0_OUT0#13	I2C0_SDA#13		
		LETIM0_OUT1#12	I2C0_SCL #12		
		PCNT0_S0IN#13			
		PCNT0_S1IN #12			

GPIO Name	Pin Alternate Functionality / Description				
	Analog	Timers	Communication	Radio	Other
PC9	BUSAY BUSBX	TIM0_CC0#14			
		TIM0_CC1#13			
		TIM0_CC2 #12	US0_TX#14		
		TIM0_CDTI0#11	US0_RX#13		
		TIM0_CDTI1#10	US0_CLK#12		
		TIM0_CDTI2#9	US0_CS#11		
		TIM1_CC0#14	US0_CTS#10		
		TIM1_CC1#13	US0_RTS#9	FRC_DCLK#14	PRS_CH0#11
		TIM1_CC2#12	US1_TX#14	FRC_DOUT #13	PRS_CH9#14
		TIM1_CC3 #11	US1_RX#13	FRC_DFRAME#12	PRS_CH10#3
		WTIM0_CC0#29	US1_CLK#12	MODEM_DCLK #14	PRS_CH11#2
		WTIM0_CC1#27	US1_CS#11	MODEM_DIN #13	ACMP0_O#14
		WTIM0_CC2 #25	US1_CTS#10	MODEM_DOUT #12	ACMP1_O #14
		WTIM0_CDTI0#21	US1_RTS#9		ETM_TD2
		WTIM0_CDTI1#19	LEU0_TX#14		
		WTIM0_CDTI2#17	LEU0_RX#13		
		LETIM0_OUT0#14	I2C0_SDA#14		
		LETIM0_OUT1#13	I2C0_SCL #13		
		PCNT0_S0IN#14			
		PCNT0_S1IN #13			

GPIO Name	Pin Alternate Functionality / Description				
	Analog	Timers	Communication	Radio	Other
PC10	BUSBY BUSAX	TIM0_CC0#15			
		TIM0_CC1#14	US0_TX#15		
		TIM0_CC2 #13	US0_RX#14		
		TIM0_CDTI0#12	US0_CLK#13		
		TIM0_CDTI1#11	US0_CS#12		
		TIM0_CDTI2 #10	US0_CTS#11		
		TIM1_CC0#15	US0_RTS #10		
		TIM1_CC1#14	US1_TX#15	FRC_DCLK#15	
		TIM1_CC2#13	US1_RX#14	FRC_DOUT #14	
		TIM1_CC3 #12	US1_CLK#13	FRC_DFRAME#13	
		WTIM0_CC0#30	US1_CS#12	MODEM_DCLK #15	
		WTIM0_CC1#28	US1_CTS#11	MODEM_DIN #14	
		WTIM0_CC2 #26	US1_RTS#10	MODEM_DOUT #13	
		WTIM0_CDTI0#22	LEU0_TX#15		
		WTIM0_CDTI1 #20	LEU0_RX#14		
		WTIM0_CDTI2#18	I2C0_SDA#15		
		LETIM0_OUT0#15	I2C0_SCL#14		
		LETIM0_OUT1#14	I2C1_SDA#19		
		PCNT0_S0IN#15	I2C1_SCL #18		
		PCNT0_S1IN #14			

GPIO Name	Pin Alternate Functionality / Description				
	Analog	Timers	Communication	Radio	Other
PC11		TIM0_CC0#16			
		TIM0_CC1#15	US0_TX#16		
		TIM0_CC2 #14	US0_RX#15		
		TIM0_CDTI0#13	US0_CLK#14		
		TIM0_CDTI1#12	US0_CS#13		
		TIM0_CDTI2 #11	US0_CTS#12		
		TIM1_CC0#16	US0_RTS #11		CMU_CLK0#3
		TIM1_CC1#15	US1_TX#16	FRC_DCLK#16	PRS_CH0#13
		TIM1_CC2#14	US1_RX#15	FRC_DOUT #15	PRS_CH9#16
	BUSAY	TIM1_CC3 #13	US1_CLK#14	FRC_DFRAME#14	PRS_CH10#5
	BUSBX	WTIM0_CC0#31	US1_CS#13	MODEM_DCLK #16	PRS_CH11#4
		WTIM0_CC1#29	US1_CTS#12	MODEM_DIN #15	ACMP0_O#16
		WTIM0_CC2 #27	US1_RTS#11	MODEM_DOUT #14	ACMP1_O#16
		WTIM0_CDTI0#23	LEU0_TX#16		DBG_SWO #3
		WTIM0_CDTI1 #21	LEU0_RX#15		
		WTIM0_CDTI2#19	I2C0_SDA#16		
		LETIM0_OUT0#16	I2C0_SCL#15		
		LETIM0_OUT1#15	I2C1_SDA#20		
		PCNT0_S0IN#16	I2C1_SCL #19		
		PCNT0_S1IN #15			

GPIO Name	Pin Alternate Functionality / Description					
	Analog	Timers	Communication	Radio	Other	
PD9	BUSCY BUSDX	TIM0_CC0#17				
		TIM0_CC1#16				
		TIM0_CC2 #15		US0_TX#17		
		TIM0_CDTI0#14		US0_RX#16		
		TIM0_CDTI1#13		US0_CLK#15		
		TIM0_CDTI2 #12		US0_CS#14		
		TIM1_CC0#17		US0_CTS#13		CMU_CLK0#4
		TIM1_CC1#16		US0_RTS #12	FRC_DCLK#17	PRS_CH3#8
		TIM1_CC2#15		US1_TX#17	FRC_DOUT #16	PRS_CH4#0
		TIM1_CC3 #14		US1_RX#16	FRC_DFRAME#15	PRS_CH5#6
		WTIM0_CC1#31		US1_CLK#15	MODEM_DCLK #17	PRS_CH6#11
		WTIM0_CC2 #29		US1_CS#14	MODEM_DIN #16	ACMP0_O
		WTIM0_CDTI0#25		US1_CTS#13	MODEM_DOUT #15	#17
		WTIM0_CDTI1#23		US1_RTS#12		ACMP1_O
		WTIM0_CDTI2#21		LEU0_TX#17		#17
		LETIM0_OUT0#17		LEU0_RX#16		LES_CH1
		LETIM0_OUT1#16		I2C0_SDA#17		
		PCNT0_S0IN#17		I2C0_SCL #16		
		PCNT0_S1IN #16				

GPIO Name	Pin Alternate Functionality / Description				
	Analog	Timers	Communication	Radio	Other
PD10		TIM0_CC0#18			
		TIM0_CC1#17	US0_TX#18		
		TIM0_CC2 #16	US0_RX#17		
		TIM0_CDTI0#15	US0_CLK#16		
		TIM0_CDTI1#14	US0_CS#15		
		TIM0_CDTI2 #13	US0_CTS#14		CMU_CLK1 #4
		TIM1_CC0#18	US0_RTS #13	FRC_DCLK#18	PRS_CH3#9
		TIM1_CC1#17	US1_TX#18	FRC_DOUT #17	PRS_CH4#1
	BUSDY	TIM1_CC2#16	US1_RX#17	FRC_DFRAME #16	PRS_CH5#0
	BUSCX	TIM1_CC3 #15	US1_CLK#16	MODEM_DCLK #18	PRS_CH6#12
		WTIM0_CC2#30	US1_CS#15	MODEM_DIN #17	ACMP0_O
		WTIM0_CDTI0#26	US1_CTS#14	MODEM_DOUT #16	#18
		WTIM0_CDTI1 #24	US1_RTS#13		ACMP1_O
		WTIM0_CDTI2#22	LEU0_TX#18		#18
		LETIM0_OUT0#18	LEU0_RX#17		LES_CH2
		LETIM0_OUT1#17	I2C0_SDA#18		
		PCNT0_S0IN#18	I2C0_SCL #17		
		PCNT0_S1IN #17			

GPIO Name	Pin Alternate Functionality / Description				
	Analog	Timers	Communication	Radio	Other
PD11	BUSCY BUSDX	TIM0_CC0#19			
		TIM0_CC1#18	US0_TX#19		
		TIM0_CC2 #17	US0_RX#18		
		TIM0_CDTI0#16	US0_CLK#17		
		TIM0_CDTI1#15	US0_CS#16		
		TIM0_CDTI2 #14	US0_CTS#15		
		TIM1_CC0#19	US0_RTS #14	FRC_DCLK#19	PRS_CH3#10
		TIM1_CC1#18	US1_TX#19	FRC_DOUT #18	PRS_CH4 #2
		TIM1_CC2#17	US1_RX#18	FRC_DFRAME #17	PRS_CH5#1
		TIM1_CC3 #16	US1_CLK#17	MODEM_DCLK #19	PRS_CH6#13
		WTIM0_CC2#31	US1_CS#16	MODEM_DIN #18	ACMP0_O #19
		WTIM0_CDTI0#27	US1_CTS#15	MODEM_DOUT #17	ACMP1_O #19
		WTIM0_CDTI1 #25	US1_RTS#14		LES_CH3
		WTIM0_CDTI2#23	LEU0_TX#19		
		LETIM0_OUT0#19	LEU0_RX#18		
		LETIM0_OUT1#18	I2C0_SDA#19		
PCNT0_S0IN#19	I2C0_SCL #18				
PCNT0_S1IN #18					
PD12	VDAC0_OUT1ALT/ OPA1_OUTALT #0 BUSDY BUSCX	TIM0_CC0#20	US0_TX#20		
		TIM0_CC1#19	US0_RX#19		
		TIM0_CC2 #18	US0_CLK#18		
		TIM0_CDTI0#17	US0_CS#17		
		TIM0_CDTI1#16	US0_CTS#16		
		TIM0_CDTI2 #15	US0_RTS #15	FRC_DCLK#20	PRS_CH3#11
		TIM1_CC0#20	US1_TX#20	FRC_DOUT #19	PRS_CH4 #3
		TIM1_CC1#19	US1_RX#19	FRC_DFRAME #18	PRS_CH5#2
		TIM1_CC2#18	US1_CLK#18	MODEM_DCLK #20	PRS_CH6#14
		TIM1_CC3 #17	US1_CS#17	MODEM_DIN #19	ACMP0_O #20
		WTIM0_CDTI0#28	US1_CTS#16	MODEM_DOUT #18	ACMP1_O #20
		WTIM0_CDTI1 #26	US1_RTS#15		LES_CH4
		WTIM0_CDTI2#24	LEU0_TX#20		
		LETIM0_OUT0#20	LEU0_RX#19		
		LETIM0_OUT1#19	I2C0_SDA#20		
		PCNT0_S0IN#20	I2C0_SCL #19		
PCNT0_S1IN #19					

GPIO Name	Pin Alternate Functionality / Description				
	Analog	Timers	Communication	Radio	Other
PD13	VDAC0_OUT0ALT / OPA0_OUTALT #1 BUSCY BUSDX OPA1_P	TIM0_CC0#21 TIM0_CC1#20 TIM0_CC2 #19 TIM0_CDTI0#18 TIM0_CDTI1#17 TIM0_CDTI2 #16 TIM1_CC0#21 TIM1_CC1#20 TIM1_CC2#19 TIM1_CC3 #18 WTIM0_CDTI0#29 WTIM0_CDTI1#27 WTIM0_CDTI2#25 LETIM0_OUT0#21 LETIM0_OUT1#20 PCNT0_S0IN#21 PCNT0_S1IN #20	US0_TX#21 US0_RX#20 US0_CLK#19 US0_CS#18 US0_CTS#17 US0_RTS #16 US1_TX#21 US1_RX#20 US1_CLK#19 US1_CS#18 US1_CTS#17 US1_RTS#16 LEU0_TX#21 LEU0_RX#20 I2C0_SDA#21 I2C0_SCL #20	FRC_DCLK#21 FRC_DOUT #20 FRC_DFRAME #19 MODEM_DCLK #21 MODEM_DIN #20 MODEM_DOUT #19	PRS_CH3#12 PRS_CH4 #4 PRS_CH5#3 PRS_CH6#15 ACMP0_O #21 ACMP1_O #21 LES_CH5
PD14	BUSDY BUSCX VDAC0_OUT1 / OPA1_OUT	TIM0_CC0#22 TIM0_CC1#21 TIM0_CC2 #20 TIM0_CDTI0#19 TIM0_CDTI1#18 TIM0_CDTI2 #17 TIM1_CC0#22 TIM1_CC1#21 TIM1_CC2#20 TIM1_CC3 #19 WTIM0_CDTI0#30 WTIM0_CDTI1 #28 WTIM0_CDTI2#26 LETIM0_OUT0#22 LETIM0_OUT1#21 PCNT0_S0IN#22 PCNT0_S1IN #21	US0_TX#22 US0_RX#21 US0_CLK#20 US0_CS#19 US0_CTS#18 US0_RTS #17 US1_TX#22 US1_RX#21 US1_CLK#20 US1_CS#19 US1_CTS#18 US1_RTS#17 LEU0_TX#22 LEU0_RX#21 I2C0_SDA#22 I2C0_SCL #21	FRC_DCLK #22 FRC_DOUT#21 FRC_DFRAME #20 MODEM_DCLK #22 MODEM_DIN #21 MODEM_DOUT #20	CMU_CLK0#5 PRS_CH3#13 PRS_CH4 #5 PRS_CH5 #4 PRS_CH6#16 ACMP0_O#22 ACMP1_O #22 LES_CH6 GPIO_EM4WU4

GPIO Name	Pin Alternate Functionality / Description				
	Analog	Timers	Communication	Radio	Other
PD15	VDAC0_OUT0ALT / OPA0_OUTALT #2 BUSCY BUSDX OPA1_N	TIM0_CC0#23	US0_TX#23		
		TIM0_CC1#22	US0_RX#22		
		TIM0_CC2 #21	US0_CLK#21		
		TIM0_CDTI0#20	US0_CS#20		
		TIM0_CDTI1#19	US0_CTS#19		CMU_CLK1 #5
		TIM0_CDTI2 #18	US0_RTS #18	FRC_DCLK#23	PRS_CH3#14
		TIM1_CC0#23	US1_TX#23	FRC_DOUT #22	PRS_CH4 #6
		TIM1_CC1#22	US1_RX#22	FRC_DFRAME #21	PRS_CH5#5
		TIM1_CC2#21	US1_CLK#21	MODEM_DCLK #23	PRS_CH6#17
		TIM1_CC3 #20	US1_CS#20	MODEM_DIN #22	ACMP0_O#23
		WTIM0_CDTI0#31	US1_CTS#19	MODEM_DOUT #21	ACMP1_O #23
		WTIM0_CDTI1 #29	US1_RTS#18		LES_CH7
		WTIM0_CDTI2#27	LEU0_TX#23		DBG_SWO #2
		LETIM0_OUT0#23	LEU0_RX#22		
		LETIM0_OUT1#22	I2C0_SDA#23		
		PCNT0_S0IN#23	I2C0_SCL #22		
		PCNT0_S1IN #22			

GPIO Name	Pin Alternate Functionality / Description					
	Analog	Timers	Communication	Radio	Other	
PF0	BUSBY BUSAX		US0_TX#24			
			US0_RX#23			
			US0_CLK#22			
			TIM0_CC0#24	US0_CS#21		
			TIM0_CC1#23	US0_CTS#20		
			TIM0_CC2#22	US0_RTS#19		
			TIM0_CDTI0#21	US1_TX#24		
			TIM0_CDTI1#20	US1_RX#23		
			TIM0_CDTI2#19	US1_CLK#22	FRC_DCLK#24	PRS_CH0#0
			TIM1_CC0#24	US1_CS#21	FRC_DOUT#23	PRS_CH1#7
			TIM1_CC1#23	US1_CTS#20	FRC_DFRAME#22	PRS_CH2#6
			TIM1_CC2#22	US1_RTS#19	MODEM_DCLK#24	PRS_CH3#5
			TIM1_CC3#21	US2_TX#14	MODEM_DIN#23	ACMP0_O#24
			WTIM0_CDTI1#30	US2_RX#13	MODEM_DOUT#22	ACMP1_O#24
			WTIM0_CDTI2#28	US2_CLK#12		DBG_SWCLKTCK
			LETIM0_OUT0#24	US2_CS#11		
			LETIM0_OUT1#23	US2_CTS#10		
			PCNT0_S0IN#24	US2_RTS#9		
			PCNT0_S1IN#23	LEU0_TX#24		
				LEU0_RX#23		
				I2C0_SDA#24		
				I2C0_SCL#23		

GPIO Name	Pin Alternate Functionality / Description				
	Analog	Timers	Communication	Radio	Other
PF1	BUSAY BUSBX		US0_TX#25		
			US0_RX#24		
			US0_CLK#23		
		TIM0_CC0#25	US0_CS#22		
		TIM0_CC1#24	US0_CTS#21		
		TIM0_CC2#23	US0_RTS#20		
		TIM0_CDTI0#22	US1_TX#25		
		TIM0_CDTI1#21	US1_RX#24		
		TIM0_CDTI2#20	US1_CLK#23	FRC_DCLK#25	PRS_CH0#1
		TIM1_CC0#25	US1_CS#22	FRC_DOUT#24	PRS_CH1#0
		TIM1_CC1#24	US1_CTS#21	FRC_DFRAME#23	PRS_CH2#7
		TIM1_CC2#23	US1_RTS#20	MODEM_DCLK#25	PRS_CH3#6
		TIM1_CC3#22	US2_TX#15	MODEM_DIN#24	ACMP0_O#25
		WTIM0_CDTI1#31	US2_RX#14	MODEM_DOUT#23	ACMP1_O#25
		WTIM0_CDTI2#29	US2_CLK#13		DBG_SWDIOTMS
		LETIM0_OUT0#25	US2_CS#12		
		LETIM0_OUT1#24	US2_CTS#11		
		PCNT0_S0IN#25	US2_RTS#10		
		PCNT0_S1IN#24	LEU0_TX#25		
			LEU0_RX#24		
	I2C0_SDA#25				
	I2C0_SCL#24				

GPIO Name	Pin Alternate Functionality / Description				
	Analog	Timers	Communication	Radio	Other
PF2	BUSBY BUSAX	TIM0_CC0#26	US0_TX#26		
		TIM0_CC1#25	US0_RX#25		
		TIM0_CC2#24	US0_CLK#24		
		TIM0_CDTI0#23	US0_CS#23		CMU_CLK0#6
		TIM0_CDTI1#22	US0_CTS#22		PRS_CH0#2
		TIM0_CDTI2#21	US0_RTS#21	FRC_DCLK#26	PRS_CH1#1
		TIM1_CC0#26	US1_TX#26	FRC_DOUT#25	PRS_CH2#0
		TIM1_CC1#25	US1_RX#25	FRC_DFRAME#24	PRS_CH3#7
		TIM1_CC2#24	US1_CLK#24	MODEM_DCLK#26	ACMP0_O#26
		TIM1_CC3#23	US1_CS#23	MODEM_DIN#25	ACMP1_O#26
		WTIM0_CDTI2#30	US1_CTS#22	MODEM_DOUT#24	DBG_TDO
		LETIM0_OUT0#26	US1_RTS#21		DBG_SWO#0
		LETIM0_OUT1#25	LEU0_TX#26		GPIO_EM4WU0
		PCNT0_S0IN#26	LEU0_RX#25		
		PCNT0_S1IN#25	I2C0_SDA#26		
			I2C0_SCL#25		

GPIO Name	Pin Alternate Functionality / Description					
	Analog	Timers	Communication	Radio	Other	
PF3	BUSAY BUSBX		US0_TX#27			
			US0_RX#26			
			US0_CLK#25			
			US0_CS#24			
			TIM0_CC0#27	US0_CTS#23		
			TIM0_CC1#26	US0_RTS#22		
			TIM0_CC2#25	US1_TX#27		
			TIM0_CDTI0#24	US1_RX#26		CMU_CLK1#6
			TIM0_CDTI1#23	US1_CLK#25	FRC_DCLK#27	PRS_CH0#3
			TIM0_CDTI2#22	US1_CS#24	FRC_DOUT#26	PRS_CH1#2
			TIM1_CC0#27	US1_CTS#23	FRC_DFRAME#25	PRS_CH2#1
			TIM1_CC1#26	US1_RTS#22	MODEM_DCLK#27	PRS_CH3#0
			TIM1_CC2#25	US2_TX#16	MODEM_DIN#26	ACMP0_O#27
			TIM1_CC3#24	US2_RX#15	MODEM_DOUT#25	ACMP1_O#27
			WTIM0_CDTI2#31	US2_CLK#14		DBG_TDI
			LETIM0_OUT0#27	US2_CS#13		
			LETIM0_OUT1#26	US2_CTS#12		
			PCNT0_S0IN#27	US2_RTS#11		
			PCNT0_S1IN#26	LEU0_TX#27		
				LEU0_RX#26		
				I2C0_SDA#27		
				I2C0_SCL#26		

GPIO Name	Pin Alternate Functionality / Description					
	Analog	Timers	Communication	Radio	Other	
PF4	BUSBY BUSAX		US0_TX#28			
			US0_RX#27			
			US0_CLK#26			
			US0_CS#25			
			TIM0_CC0#28	US0_CTS#24		
			TIM0_CC1#27	US0_RTS#23		
			TIM0_CC2#26	US1_TX#28		
			TIM0_CDTI0#25	US1_RX#27		
			TIM0_CDTI1#24	US1_CLK#26	FRC_DCLK#28	PRS_CH0#4
			TIM0_CDTI2#23	US1_CS#25	FRC_DOUT#27	PRS_CH1#3
			TIM1_CC0#28	US1_CTS#24	FRC_DFRAME#26	PRS_CH2#2
			TIM1_CC1#27	US1_RTS#23	MODEM_DCLK#28	PRS_CH3#1
			TIM1_CC2#26	US2_TX#17	MODEM_DIN#27	ACMP0_O#28
			TIM1_CC3#25	US2_RX#16	MODEM_DOUT#26	ACMP1_O#28
			LETIM0_OUT0#28	US2_CLK#15		
			LETIM0_OUT1#27	US2_CS#14		
			PCNT0_S0IN#28	US2_CTS#13		
			PCNT0_S1IN#27	US2_RTS#12		
				LEU0_TX#28		
				LEU0_RX#27		
				I2C0_SDA#28		
				I2C0_SCL#27		

GPIO Name	Pin Alternate Functionality / Description					
	Analog	Timers	Communication	Radio	Other	
PF5	BUSAY BUSBX		US0_TX#29			
			US0_RX#28			
			US0_CLK#27			
			US0_CS#26			
			TIM0_CC0#29	US0_CTS#25		
			TIM0_CC1#28	US0_RTS#24		
			TIM0_CC2#27	US1_TX#29		
			TIM0_CDTI0#26	US1_RX#28		
			TIM0_CDTI1#25	US1_CLK#27	FRC_DCLK#29	PRS_CH0#5
			TIM0_CDTI2#24	US1_CS#26	FRC_DOUT#28	PRS_CH1#4
			TIM1_CC0#29	US1_CTS#25	FRC_DFRAME#27	PRS_CH2#3
			TIM1_CC1#28	US1_RTS#24	MODEM_DCLK#29	PRS_CH3#2
			TIM1_CC2#27	US2_TX#18	MODEM_DIN#28	ACMP0_O#29
			TIM1_CC3#26	US2_RX#17	MODEM_DOUT#27	ACMP1_O#29
			LETIM0_OUT0#29	US2_CLK#16		
			LETIM0_OUT1#28	US2_CS#15		
			PCNT0_S0IN#29	US2_CTS#14		
			PCNT0_S1IN#28	US2_RTS#13		
				LEU0_TX#29		
				LEU0_RX#28		
		I2C0_SDA#29				
		I2C0_SCL#28				

GPIO Name	Pin Alternate Functionality / Description					
	Analog	Timers	Communication	Radio	Other	
PF6	BUSBY BUSAX		US0_TX#30			
			US0_RX#29			
			US0_CLK#28			
			US0_CS#27			
			TIM0_CC0#30	US0_CTS#26		
			TIM0_CC1#29	US0_RTS#25		
			TIM0_CC2#28	US1_TX#30		
			TIM0_CDTI0#27	US1_RX#29		
			TIM0_CDTI1#26	US1_CLK#28	FRC_DCLK#30	CMU_CLK1#7
			TIM0_CDTI2#25	US1_CS#27	FRC_DOUT#29	PRS_CH0#6
			TIM1_CC0#30	US1_CTS#26	FRC_DFRAME#28	PRS_CH1#5
			TIM1_CC1#29	US1_RTS#25	MODEM_DCLK#30	PRS_CH2#4
			TIM1_CC2#28	US2_TX#19	MODEM_DIN#29	PRS_CH3#3
			TIM1_CC3#27	US2_RX#18	MODEM_DOUT#28	ACMP0_O#30
			LETIM0_OUT0#30	US2_CLK#17		ACMP1_O#30
			LETIM0_OUT1#29	US2_CS#16		
			PCNT0_S0IN#30	US2_CTS#15		
			PCNT0_S1IN#29	US2_RTS#14		
				LEU0_TX#30		
				LEU0_RX#29		
				I2C0_SDA#30		
				I2C0_SCL#29		

GPIO Name	Pin Alternate Functionality / Description					
	Analog	Timers	Communication	Radio	Other	
PF7	BUSAY BUSBX		US0_TX#31			
			US0_RX#30			
			US0_CLK#29			
			US0_CS#28			
			TIM0_CC0#31	US0_CTS#27		
			TIM0_CC1#30	US0_RTS#26		
			TIM0_CC2#29	US1_TX#31		
			TIM0_CDTI0#28	US1_RX#30		CMU_CLKI0#1
			TIM0_CDTI1#27	US1_CLK#29	FRC_DCLK#31	CMU_CLK0#7
			TIM0_CDTI2#26	US1_CS#28	FRC_DOUT#30	PRS_CH0#7
			TIM1_CC0#31	US1_CTS#27	FRC_DFRAME#29	PRS_CH1#6
			TIM1_CC1#30	US1_RTS#26	MODEM_DCLK#31	PRS_CH2#5
			TIM1_CC2#29	US2_TX#20	MODEM_DIN#30	PRS_CH3#4
			TIM1_CC3#28	US2_RX#19	MODEM_DOUT#29	ACMP0_O#31
			LETIM0_OUT0#31	US2_CLK#18		ACMP1_O#31
			LETIM0_OUT1#30	US2_CS#17		GPIO_EM4WU1
			PCNT0_S0IN#31	US2_CTS#16		
			PCNT0_S1IN#30	US2_RTS#15		
				LEU0_TX#31		
				LEU0_RX#30		
		I2C0_SDA#31				
		I2C0_SCL#30				

6.3 Alternate Functionality Overview

A wide selection of alternate functionality is available for multiplexing to various pins. The following table shows the name of the alternate functionality in the first column, followed by columns showing the possible LOCATION bitfield settings and the associated GPIO pin. Refer to [6.2 GPIO Functionality Table](#) for a list of functions available on each GPIO pin.

Note: Some functionality, such as analog interfaces, do not have alternate settings or a LOCATION bitfield. In these cases, the pinout is shown in the column corresponding to LOCATION 0.

Table 6.3. Alternate Functionality Overview

Alternate Functionality	LOCATION								Description
	0 - 3	4 - 7	8 - 11	12 - 15	16 - 19	20 - 23	24 - 27	28 - 31	
ACMP0_O	0: PA0 1: PA1 2: PA2 3: PA3	4: PA4 5: PA5 6: PB11 7: PB12	8: PB13 9: PB14 10: PB15 11: PC6	12: PC7 13: PC8 14: PC9 15: PC10	16: PC11 17: PD9 18: PD10 19: PD11	20: PD12 21: PD13 22: PD14 23: PD15	24: PF0 25: PF1 26: PF2 27: PF3	28: PF4 29: PF5 30: PF6 31: PF7	Analog comparator ACMP0, digital out- put.
ACMP1_O	0: PA0 1: PA1 2: PA2 3: PA3	4: PA4 5: PA5 6: PB11 7: PB12	8: PB13 9: PB14 10: PB15 11: PC6	12: PC7 13: PC8 14: PC9 15: PC10	16: PC11 17: PD9 18: PD10 19: PD11	20: PD12 21: PD13 22: PD14 23: PD15	24: PF0 25: PF1 26: PF2 27: PF3	28: PF4 29: PF5 30: PF6 31: PF7	Analog comparator ACMP1, digital out- put.
ADC0_EXTN	0: PA0								Analog to digital converter ADC0 ex- ternal reference in- put negative pin.
ADC0_EXTP	0: PA1								Analog to digital converter ADC0 ex- ternal reference in- put positive pin.
CMU_CLK0	0: PA1 1: PB15 2: PC6 3: PC11	4: PD9 5: PD14 6: PF2 7: PF7							Clock Management Unit, clock output number 0.
CMU_CLK1	0: PA0 1: PB14 2: PC7 3: PC10	4: PD10 5: PD15 6: PF3 7: PF6							Clock Management Unit, clock output number 1.
CMU_CLKI0	0: PB13 1: PF7 2: PC6	4: PA5							Clock Management Unit, clock input number 0.

Alternate	LOCATION								
Functionality	0 - 3	4 - 7	8 - 11	12 - 15	16 - 19	20 - 23	24 - 27	28 - 31	Description
DBG_SWCLKTCK	0: PF0								Debug-interface Serial Wire clock input and JTAG Test Clock. Note that this function is enabled to the pin out of reset, and has a built-in pull down.
DBG_SWDIOTMS	0: PF1								Debug-interface Serial Wire data input / output and JTAG Test Mode Select. Note that this function is enabled to the pin out of reset, and has a built-in pull up.
DBG_SWO	0: PF2 1: PB13 2: PD15 3: PC11								Debug-interface Serial Wire viewer Output. Note that this function is not enabled after reset, and must be enabled by software to be used.
DBG_TDI	0: PF3								Debug-interface JTAG Test Data In. Note that this function becomes available after the first valid JTAG command is received, and has a built-in pull up when JTAG is active.
DBG_TDO	0: PF2								Debug-interface JTAG Test Data Out. Note that this function becomes available after the first valid JTAG command is received.
ETM_TCLK	1: PA5 3: PC6								Embedded Trace Module ETM clock .
ETM_TDO	3: PC7								Embedded Trace Module ETM data 0.

Alternate	LOCATION								
Functionality	0 - 3	4 - 7	8 - 11	12 - 15	16 - 19	20 - 23	24 - 27	28 - 31	Description
ETM_TD1	3: PC8								Embedded Trace Module ETM data 1.
ETM_TD2	3: PC9								Embedded Trace Module ETM data 2.
ETM_TD3	3: PC10								Embedded Trace Module ETM data 3.
FRC_DCLK	0: PA0 1: PA1 2: PA2 3: PA3	4: PA4 5: PA5 6: PB11 7: PB12	8: PB13 9: PB14 10: PB15 11: PC6	12: PC7 13: PC8 14: PC9 15: PC10	16: PC11 17: PD9 18: PD10 19: PD11	20: PD12 21: PD13 22: PD14 23: PD15	24: PF0 25: PF1 26: PF2 27: PF3	28: PF4 29: PF5 30: PF6 31: PF7	Frame Controller, Data Sniffer Clock.
FRC_DFRAME	0: PA2 1: PA3 2: PA4 3: PA5	4: PB11 5: PB12 6: PB13 7: PB14	8: PB15 9: PC6 10: PC7 11: PC8	12: PC9 13: PC10 14: PC11 15: PD9	16: PD10 17: PD11 18: PD12 19: PD13	20: PD14 21: PD15 22: PF0 23: PF1	24: PF2 25: PF3 26: PF4 27: PF5	28: PF6 29: PF7 30: PA0 31: PA1	Frame Controller, Data Sniffer Frame active
FRC_DOUT	0: PA1 1: PA2 2: PA3 3: PA4	4: PA5 5: PB11 6: PB12 7: PB13	8: PB14 9: PB15 10: PC6 11: PC7	12: PC8 13: PC9 14: PC10 15: PC11	16: PD9 17: PD10 18: PD11 19: PD12	20: PD13 21: PD14 22: PD15 23: PF0	24: PF1 25: PF2 26: PF3 27: PF4	28: PF5 29: PF6 30: PF7 31: PA0	Frame Controller, Data Sniffer Output.
GPIO_EM4WU0	0: PF2								Pin can be used to wake the system up from EM4
GPIO_EM4WU1	0: PF7								Pin can be used to wake the system up from EM4
GPIO_EM4WU4	0: PD14								Pin can be used to wake the system up from EM4
GPIO_EM4WU8	0: PA3								Pin can be used to wake the system up from EM4
GPIO_EM4WU9	0: PB13								Pin can be used to wake the system up from EM4
GPIO_EM4WU12	0: PC10								Pin can be used to wake the system up from EM4
I2C0_SCL	0: PA1 1: PA2 2: PA3 3: PA4	4: PA5 5: PB11 6: PB12 7: PB13	8: PB14 9: PB15 10: PC6 11: PC7	12: PC8 13: PC9 14: PC10 15: PC11	16: PD9 17: PD10 18: PD11 19: PD12	20: PD13 21: PD14 22: PD15 23: PF0	24: PF1 25: PF2 26: PF3 27: PF4	28: PF5 29: PF6 30: PF7 31: PA0	I2C0 Serial Clock Line input / output.

Alternate	LOCATION								
Functionality	0 - 3	4 - 7	8 - 11	12 - 15	16 - 19	20 - 23	24 - 27	28 - 31	Description
I2C0_SDA	0: PA0 1: PA1 2: PA2 3: PA3	4: PA4 5: PA5 6: PB11 7: PB12	8: PB13 9: PB14 10: PB15 11: PC6	12: PC7 13: PC8 14: PC9 15: PC10	16: PC11 17: PD9 18: PD10 19: PD11	20: PD12 21: PD13 22: PD14 23: PD15	24: PF0 25: PF1 26: PF2 27: PF3	28: PF4 29: PF5 30: PF6 31: PF7	I2C0 Serial Data input / output.
I2C1_SCL					18: PC10 19: PC11				I2C1 Serial Clock Line input / output.
I2C1_SDA					19: PC10	20: PC11			I2C1 Serial Data input / output.
LES_CH1	0: PD9								LESENSE channel 1.
LES_CH2	0: PD10								LESENSE channel 2.
LES_CH3	0: PD11								LESENSE channel 3.
LES_CH4	0: PD12								LESENSE channel 4.
LES_CH5	0: PD13								LESENSE channel 5.
LES_CH6	0: PD14								LESENSE channel 6.
LES_CH7	0: PD15								LESENSE channel 7.
LES_CH8	0: PA0								LESENSE channel 8.
LES_CH9	0: PA1								LESENSE channel 9.
LES_CH10	0: PA2								LESENSE channel 10.
LES_CH11	0: PA3								LESENSE channel 11.
LES_CH12	0: PA4								LESENSE channel 12.
LES_CH13	0: PA5								LESENSE channel 13.
LETIM0_OUT0	0: PA0 1: PA1 2: PA2 3: PA3	4: PA4 5: PA5 6: PB11 7: PB12	8: PB13 9: PB14 10: PB15 11: PC6	12: PC7 13: PC8 14: PC9 15: PC10	16: PC11 17: PD9 18: PD10 19: PD11	20: PD12 21: PD13 22: PD14 23: PD15	24: PF0 25: PF1 26: PF2 27: PF3	28: PF4 29: PF5 30: PF6 31: PF7	Low Energy Timer LETIM0, output channel 0.
LETIM0_OUT1	0: PA1 1: PA2 2: PA3 3: PA4	4: PA5 5: PB11 6: PB12 7: PB13	8: PB14 9: PB15 10: PC6 11: PC7	12: PC8 13: PC9 14: PC10 15: PC11	16: PD9 17: PD10 18: PD11 19: PD12	20: PD13 21: PD14 22: PD15 23: PF0	24: PF1 25: PF2 26: PF3 27: PF4	28: PF5 29: PF6 30: PF7 31: PA0	Low Energy Timer LETIM0, output channel 1.

Alternate	LOCATION								
Functionality	0 - 3	4 - 7	8 - 11	12 - 15	16 - 19	20 - 23	24 - 27	28 - 31	Description
LEU0_RX	0: PA1 1: PA2 2: PA3 3: PA4	4: PA5 5: PB11 6: PB12 7: PB13	8: PB14 9: PB15 10: PC6 11: PC7	12: PC8 13: PC9 14: PC10 15: PC11	16: PD9 17: PD10 18: PD11 19: PD12	20: PD13 21: PD14 22: PD15 23: PF0	24: PF1 25: PF2 26: PF3 27: PF4	28: PF5 29: PF6 30: PF7 31: PA0	LEUART0 Receive input.
LEU0_TX	0: PA0 1: PA1 2: PA2 3: PA3	4: PA4 5: PA5 6: PB11 7: PB12	8: PB13 9: PB14 10: PB15 11: PC6	12: PC7 13: PC8 14: PC9 15: PC10	16: PC11 17: PD9 18: PD10 19: PD11	20: PD12 21: PD13 22: PD14 23: PD15	24: PF0 25: PF1 26: PF2 27: PF3	28: PF4 29: PF5 30: PF6 31: PF7	LEUART0 Transmit output. Also used as receive input in half duplex communication.
MODEM_DCLK	0: PA0 1: PA1 2: PA2 3: PA3	4: PA4 5: PA5 6: PB11 7: PB12	8: PB13 9: PB14 10: PB15 11: PC6	12: PC7 13: PC8 14: PC9 15: PC10	16: PC11 17: PD9 18: PD10 19: PD11	20: PD12 21: PD13 22: PD14 23: PD15	24: PF0 25: PF1 26: PF2 27: PF3	28: PF4 29: PF5 30: PF6 31: PF7	MODEM data clock out.
MODEM_DIN	0: PA1 1: PA2 2: PA3 3: PA4	4: PA5 5: PB11 6: PB12 7: PB13	8: PB14 9: PB15 10: PC6 11: PC7	12: PC8 13: PC9 14: PC10 15: PC11	16: PD9 17: PD10 18: PD11 19: PD12	20: PD13 21: PD14 22: PD15 23: PF0	24: PF1 25: PF2 26: PF3 27: PF4	28: PF5 29: PF6 30: PF7 31: PA0	MODEM data in.
MODEM_DOUT	0: PA2 1: PA3 2: PA4 3: PA5	4: PB11 5: PB12 6: PB13 7: PB14	8: PB15 9: PC6 10: PC7 11: PC8	12: PC9 13: PC10 14: PC11 15: PD9	16: PD10 17: PD11 18: PD12 19: PD13	20: PD14 21: PD15 22: PF0 23: PF1	24: PF2 25: PF3 26: PF4 27: PF5	28: PF6 29: PF7 30: PA0 31: PA1	MODEM data out.
OPA0_N	0: PA4								Operational Amplifier 0 external negative input.
OPA0_P	0: PA2								Operational Amplifier 0 external positive input.
OPA1_N	0: PD15								Operational Amplifier 1 external negative input.
OPA1_P	0: PD13								Operational Amplifier 1 external positive input.
OPA2_N	0: PB13								Operational Amplifier 2 external negative input.
OPA2_OUT	0: PB12								Operational Amplifier 2 output.
OPA2_P	0: PB11								Operational Amplifier 2 external positive input.

Alternate	LOCATION								
Functionality	0 - 3	4 - 7	8 - 11	12 - 15	16 - 19	20 - 23	24 - 27	28 - 31	Description
PCNT0_S0IN	0: PA0 1: PA1 2: PA2 3: PA3	4: PA4 5: PA5 6: PB11 7: PB12	8: PB13 9: PB14 10: PB15 11: PC6	12: PC7 13: PC8 14: PC9 15: PC10	16: PC11 17: PD9 18: PD10 19: PD11	20: PD12 21: PD13 22: PD14 23: PD15	24: PF0 25: PF1 26: PF2 27: PF3	28: PF4 29: PF5 30: PF6 31: PF7	Pulse Counter PCNT0 input number 0.
PCNT0_S1IN	0: PA1 1: PA2 2: PA3 3: PA4	4: PA5 5: PB11 6: PB12 7: PB13	8: PB14 9: PB15 10: PC6 11: PC7	12: PC8 13: PC9 14: PC10 15: PC11	16: PD9 17: PD10 18: PD11 19: PD12	20: PD13 21: PD14 22: PD15 23: PF0	24: PF1 25: PF2 26: PF3 27: PF4	28: PF5 29: PF6 30: PF7 31: PA0	Pulse Counter PCNT0 input number 1.
PRS_CH0	0: PF0 1: PF1 2: PF2 3: PF3	4: PF4 5: PF5 6: PF6 7: PF7	8: PC6 9: PC7 10: PC8 11: PC9	12: PC10 13: PC11					Peripheral Reflex System PRS, channel 0.
PRS_CH1	0: PF1 1: PF2 2: PF3 3: PF4	4: PF5 5: PF6 6: PF7 7: PF0							Peripheral Reflex System PRS, channel 1.
PRS_CH2	0: PF2 1: PF3 2: PF4 3: PF5	4: PF6 5: PF7 6: PF0 7: PF1							Peripheral Reflex System PRS, channel 2.
PRS_CH3	0: PF3 1: PF4 2: PF5 3: PF6	4: PF7 5: PF0 6: PF1 7: PF2	8: PD9 9: PD10 10: PD11 11: PD12	12: PD13 13: PD14 14: PD15					Peripheral Reflex System PRS, channel 3.
PRS_CH4	0: PD9 1: PD10 2: PD11 3: PD12	4: PD13 5: PD14 6: PD15							Peripheral Reflex System PRS, channel 4.
PRS_CH5	0: PD10 1: PD11 2: PD12 3: PD13	4: PD14 5: PD15 6: PD9							Peripheral Reflex System PRS, channel 5.
PRS_CH6	0: PA0 1: PA1 2: PA2 3: PA3	4: PA4 5: PA5 6: PB11 7: PB12	8: PB13 9: PB14 10: PB15 11: PD9	12: PD10 13: PD11 14: PD12 15: PD13	16: PD14 17: PD15				Peripheral Reflex System PRS, channel 6.

Alternate	LOCATION								
Functionality	0 - 3	4 - 7	8 - 11	12 - 15	16 - 19	20 - 23	24 - 27	28 - 31	Description
PRS_CH7	0: PA1 1: PA2 2: PA3 3: PA4	4: PA5 5: PB11 6: PB12 7: PB13	8: PB14 9: PB15 10: PA0						Peripheral Reflex System PRS, channel 7.
PRS_CH8	0: PA2 1: PA3 2: PA4 3: PA5	4: PB11 5: PB12 6: PB13 7: PB14	8: PB15 9: PA0 10: PA1						Peripheral Reflex System PRS, channel 8.
PRS_CH9	0: PA3 1: PA4 2: PA5 3: PB11	4: PB12 5: PB13 6: PB14 7: PB15	8: PA0 9: PA1 10: PA2 11: PC6	12: PC7 13: PC8 14: PC9 15: PC10	16: PC11				Peripheral Reflex System PRS, channel 9.
PRS_CH10	0: PC6 1: PC7 2: PC8 3: PC9	4: PC10 5: PC11							Peripheral Reflex System PRS, channel 10.
PRS_CH11	0: PC7 1: PC8 2: PC9 3: PC10	4: PC11 5: PC6							Peripheral Reflex System PRS, channel 11.
TIM0_CC0	0: PA0 1: PA1 2: PA2 3: PA3	4: PA4 5: PA5 6: PB11 7: PB12	8: PB13 9: PB14 10: PB15 11: PC6	12: PC7 13: PC8 14: PC9 15: PC10	16: PC11 17: PD9 18: PD10 19: PD11	20: PD12 21: PD13 22: PD14 23: PD15	24: PF0 25: PF1 26: PF2 27: PF3	28: PF4 29: PF5 30: PF6 31: PF7	Timer 0 Capture Compare input / output channel 0.
TIM0_CC1	0: PA1 1: PA2 2: PA3 3: PA4	4: PA5 5: PB11 6: PB12 7: PB13	8: PB14 9: PB15 10: PC6 11: PC7	12: PC8 13: PC9 14: PC10 15: PC11	16: PD9 17: PD10 18: PD11 19: PD12	20: PD13 21: PD14 22: PD15 23: PF0	24: PF1 25: PF2 26: PF3 27: PF4	28: PF5 29: PF6 30: PF7 31: PA0	Timer 0 Capture Compare input / output channel 1.
TIM0_CC2	0: PA2 1: PA3 2: PA4 3: PA5	4: PB11 5: PB12 6: PB13 7: PB14	8: PB15 9: PC6 10: PC7 11: PC8	12: PC9 13: PC10 14: PC11 15: PD9	16: PD10 17: PD11 18: PD12 19: PD13	20: PD14 21: PD15 22: PF0 23: PF1	24: PF2 25: PF3 26: PF4 27: PF5	28: PF6 29: PF7 30: PA0 31: PA1	Timer 0 Capture Compare input / output channel 2.
TIM0_CDT10	0: PA3 1: PA4 2: PA5 3: PB11	4: PB12 5: PB13 6: PB14 7: PB15	8: PC6 9: PC7 10: PC8 11: PC9	12: PC10 13: PC11 14: PD9 15: PD10	16: PD11 17: PD12 18: PD13 19: PD14	20: PD15 21: PF0 22: PF1 23: PF2	24: PF3 25: PF4 26: PF5 27: PF6	28: PF7 29: PA0 30: PA1 31: PA2	Timer 0 Complimentary Dead Time Insertion channel 0.

Alternate	LOCATION								
Functionality	0 - 3	4 - 7	8 - 11	12 - 15	16 - 19	20 - 23	24 - 27	28 - 31	Description
TIM0_CDT11	0: PA4 1: PA5 2: PB11 3: PB12	4: PB13 5: PB14 6: PB15 7: PC6	8: PC7 9: PC8 10: PC9 11: PC10	12: PC11 13: PD9 14: PD10 15: PD11	16: PD12 17: PD13 18: PD14 19: PD15	20: PF0 21: PF1 22: PF2 23: PF3	24: PF4 25: PF5 26: PF6 27: PF7	28: PA0 29: PA1 30: PA2 31: PA3	Timer 0 Complimentary Dead Time Insertion channel 1.
TIM0_CDT12	0: PA5 1: PB11 2: PB12 3: PB13	4: PB14 5: PB15 6: PC6 7: PC7	8: PC8 9: PC9 10: PC10 11: PC11	12: PD9 13: PD10 14: PD11 15: PD12	16: PD13 17: PD14 18: PD15 19: PF0	20: PF1 21: PF2 22: PF3 23: PF4	24: PF5 25: PF6 26: PF7 27: PA0	28: PA1 29: PA2 30: PA3 31: PA4	Timer 0 Complimentary Dead Time Insertion channel 2.
TIM1_CC0	0: PA0 1: PA1 2: PA2 3: PA3	4: PA4 5: PA5 6: PB11 7: PB12	8: PB13 9: PB14 10: PB15 11: PC6	12: PC7 13: PC8 14: PC9 15: PC10	16: PC11 17: PD9 18: PD10 19: PD11	20: PD12 21: PD13 22: PD14 23: PD15	24: PF0 25: PF1 26: PF2 27: PF3	28: PF4 29: PF5 30: PF6 31: PF7	Timer 1 Capture Compare input / output channel 0.
TIM1_CC1	0: PA1 1: PA2 2: PA3 3: PA4	4: PA5 5: PB11 6: PB12 7: PB13	8: PB14 9: PB15 10: PC6 11: PC7	12: PC8 13: PC9 14: PC10 15: PC11	16: PD9 17: PD10 18: PD11 19: PD12	20: PD13 21: PD14 22: PD15 23: PF0	24: PF1 25: PF2 26: PF3 27: PF4	28: PF5 29: PF6 30: PF7 31: PA0	Timer 1 Capture Compare input / output channel 1.
TIM1_CC2	0: PA2 1: PA3 2: PA4 3: PA5	4: PB11 5: PB12 6: PB13 7: PB14	8: PB15 9: PC6 10: PC7 11: PC8	12: PC9 13: PC10 14: PC11 15: PD9	16: PD10 17: PD11 18: PD12 19: PD13	20: PD14 21: PD15 22: PF0 23: PF1	24: PF2 25: PF3 26: PF4 27: PF5	28: PF6 29: PF7 30: PA0 31: PA1	Timer 1 Capture Compare input / output channel 2.
TIM1_CC3	0: PA3 1: PA4 2: PA5 3: PB11	4: PB12 5: PB13 6: PB14 7: PB15	8: PC6 9: PC7 10: PC8 11: PC9	12: PC10 13: PC11 14: PD9 15: PD10	16: PD11 17: PD12 18: PD13 19: PD14	20: PD15 21: PF0 22: PF1 23: PF2	24: PF3 25: PF4 26: PF5 27: PF6	28: PF7 29: PA0 30: PA1 31: PA2	Timer 1 Capture Compare input / output channel 3.
US0_CLK	0: PA2 1: PA3 2: PA4 3: PA5	4: PB11 5: PB12 6: PB13 7: PB14	8: PB15 9: PC6 10: PC7 11: PC8	12: PC9 13: PC10 14: PC11 15: PD9	16: PD10 17: PD11 18: PD12 19: PD13	20: PD14 21: PD15 22: PF0 23: PF1	24: PF2 25: PF3 26: PF4 27: PF5	28: PF6 29: PF7 30: PA0 31: PA1	USART0 clock input / output.
US0_CS	0: PA3 1: PA4 2: PA5 3: PB11	4: PB12 5: PB13 6: PB14 7: PB15	8: PC6 9: PC7 10: PC8 11: PC9	12: PC10 13: PC11 14: PD9 15: PD10	16: PD11 17: PD12 18: PD13 19: PD14	20: PD15 21: PF0 22: PF1 23: PF2	24: PF3 25: PF4 26: PF5 27: PF6	28: PF7 29: PA0 30: PA1 31: PA2	USART0 chip select input / output.
US0_CTS	0: PA4 1: PA5 2: PB11 3: PB12	4: PB13 5: PB14 6: PB15 7: PC6	8: PC7 9: PC8 10: PC9 11: PC10	12: PC11 13: PD9 14: PD10 15: PD11	16: PD12 17: PD13 18: PD14 19: PD15	20: PF0 21: PF1 22: PF2 23: PF3	24: PF4 25: PF5 26: PF6 27: PF7	28: PA0 29: PA1 30: PA2 31: PA3	USART0 Clear To Send hardware flow control input.

Alternate	LOCATION								
Functionality	0 - 3	4 - 7	8 - 11	12 - 15	16 - 19	20 - 23	24 - 27	28 - 31	Description
US0_RTS	0: PA5 1: PB11 2: PB12 3: PB13	4: PB14 5: PB15 6: PC6 7: PC7	8: PC8 9: PC9 10: PC10 11: PC11	12: PD9 13: PD10 14: PD11 15: PD12	16: PD13 17: PD14 18: PD15 19: PF0	20: PF1 21: PF2 22: PF3 23: PF4	24: PF5 25: PF6 26: PF7 27: PA0	28: PA1 29: PA2 30: PA3 31: PA4	USART0 Request To Send hardware flow control output.
US0_RX	0: PA1 1: PA2 2: PA3 3: PA4	4: PA5 5: PB11 6: PB12 7: PB13	8: PB14 9: PB15 10: PC6 11: PC7	12: PC8 13: PC9 14: PC10 15: PC11	16: PD9 17: PD10 18: PD11 19: PD12	20: PD13 21: PD14 22: PD15 23: PF0	24: PF1 25: PF2 26: PF3 27: PF4	28: PF5 29: PF6 30: PF7 31: PA0	USART0 Asynchronous Receive. USART0 Synchronous mode Master Input / Slave Output (MISO).
US0_TX	0: PA0 1: PA1 2: PA2 3: PA3	4: PA4 5: PA5 6: PB11 7: PB12	8: PB13 9: PB14 10: PB15 11: PC6	12: PC7 13: PC8 14: PC9 15: PC10	16: PC11 17: PD9 18: PD10 19: PD11	20: PD12 21: PD13 22: PD14 23: PD15	24: PF0 25: PF1 26: PF2 27: PF3	28: PF4 29: PF5 30: PF6 31: PF7	USART0 Asynchronous Transmit. Also used as receive input in half duplex communication. USART0 Synchronous mode Master Output / Slave Input (MOSI).
US1_CLK	0: PA2 1: PA3 2: PA4 3: PA5	4: PB11 5: PB12 6: PB13 7: PB14	8: PB15 9: PC6 10: PC7 11: PC8	12: PC9 13: PC10 14: PC11 15: PD9	16: PD10 17: PD11 18: PD12 19: PD13	20: PD14 21: PD15 22: PF0 23: PF1	24: PF2 25: PF3 26: PF4 27: PF5	28: PF6 29: PF7 30: PA0 31: PA1	USART1 clock input / output.
US1_CS	0: PA3 1: PA4 2: PA5 3: PB11	4: PB12 5: PB13 6: PB14 7: PB15	8: PC6 9: PC7 10: PC8 11: PC9	12: PC10 13: PC11 14: PD9 15: PD10	16: PD11 17: PD12 18: PD13 19: PD14	20: PD15 21: PF0 22: PF1 23: PF2	24: PF3 25: PF4 26: PF5 27: PF6	28: PF7 29: PA0 30: PA1 31: PA2	USART1 chip select input / output.
US1_CTS	0: PA4 1: PA5 2: PB11 3: PB12	4: PB13 5: PB14 6: PB15 7: PC6	8: PC7 9: PC8 10: PC9 11: PC10	12: PC11 13: PD9 14: PD10 15: PD11	16: PD12 17: PD13 18: PD14 19: PD15	20: PF0 21: PF1 22: PF2 23: PF3	24: PF4 25: PF5 26: PF6 27: PF7	28: PA0 29: PA1 30: PA2 31: PA3	USART1 Clear To Send hardware flow control input.
US1_RTS	0: PA5 1: PB11 2: PB12 3: PB13	4: PB14 5: PB15 6: PC6 7: PC7	8: PC8 9: PC9 10: PC10 11: PC11	12: PD9 13: PD10 14: PD11 15: PD12	16: PD13 17: PD14 18: PD15 19: PF0	20: PF1 21: PF2 22: PF3 23: PF4	24: PF5 25: PF6 26: PF7 27: PA0	28: PA1 29: PA2 30: PA3 31: PA4	USART1 Request To Send hardware flow control output.
US1_RX	0: PA1 1: PA2 2: PA3 3: PA4	4: PA5 5: PB11 6: PB12 7: PB13	8: PB14 9: PB15 10: PC6 11: PC7	12: PC8 13: PC9 14: PC10 15: PC11	16: PD9 17: PD10 18: PD11 19: PD12	20: PD13 21: PD14 22: PD15 23: PF0	24: PF1 25: PF2 26: PF3 27: PF4	28: PF5 29: PF6 30: PF7 31: PA0	USART1 Asynchronous Receive. USART1 Synchronous mode Master Input / Slave Output (MISO).

Alternate	LOCATION								
Functionality	0 - 3	4 - 7	8 - 11	12 - 15	16 - 19	20 - 23	24 - 27	28 - 31	Description
US1_TX	0: PA0 1: PA1 2: PA2 3: PA3	4: PA4 5: PA5 6: PB11 7: PB12	8: PB13 9: PB14 10: PB15 11: PC6	12: PC7 13: PC8 14: PC9 15: PC10	16: PC11 17: PD9 18: PD10 19: PD11	20: PD12 21: PD13 22: PD14 23: PD15	24: PF0 25: PF1 26: PF2 27: PF3	28: PF4 29: PF5 30: PF6 31: PF7	USART1 Asynchronous Transmit. Also used as receive input in half duplex communication. USART1 Synchronous mode Master Output / Slave Input (MOSI).
US2_CLK				12: PF0 13: PF1 14: PF3 15: PF4	16: PF5 17: PF6 18: PF7			30: PA5	USART2 clock input / output.
US2_CS			11: PF0	12: PF1 13: PF3 14: PF4 15: PF5	16: PF6 17: PF7			29: PA5	USART2 chip select input / output.
US2_CTS			10: PF0 11: PF1	12: PF3 13: PF4 14: PF5 15: PF6	16: PF7			28: PA5	USART2 Clear To Send hardware flow control input.
US2_RTS			9: PF0 10: PF1 11: PF3	12: PF4 13: PF5 14: PF6 15: PF7			27: PA5		USART2 Request To Send hardware flow control output.
US2_RX				13: PF0 14: PF1 15: PF3	16: PF4 17: PF5 18: PF6 19: PF7			31: PA5	USART2 Asynchronous Receive. USART2 Synchronous mode Master Input / Slave Output (MISO).
US2_TX	0: PA5			14: PF0 15: PF1	16: PF3 17: PF4 18: PF5 19: PF6	20: PF7			USART2 Asynchronous Transmit. Also used as receive input in half duplex communication. USART2 Synchronous mode Master Output / Slave Input (MOSI).
VDAC0_EXT	0: PA1								Digital to analog converter VDAC0 external reference input pin.

Alternate	LOCATION								
Functionality	0 - 3	4 - 7	8 - 11	12 - 15	16 - 19	20 - 23	24 - 27	28 - 31	Description
VDAC0_OUT0/ OPA0_OUT	0: PA3								Digital to Analog Converter DAC0 output channel number 0.
VDAC0_OUT0ALT / OPA0_OUT- ALT	0: PA5 1: PD13 2: PD15								Digital to Analog Converter DAC0 alternative output for channel 0.
VDAC0_OUT1/ OPA1_OUT	0: PD14								Digital to Analog Converter DAC0 output channel number 1.
VDAC0_OUT1ALT / OPA1_OUT- ALT	0: PD12 1: PA2 2: PA4								Digital to Analog Converter DAC0 alternative output for channel 1.
WTIM0_CC0	0: PA0 1: PA1 2: PA2 3: PA3	4: PA4 5: PA5		15: PB11	16: PB12 17: PB13 18: PB14 19: PB15		26: PC6 27: PC7	28: PC8 29: PC9 30: PC10 31: PC11	Wide timer 0 Capture Compare input / output channel 0.
WTIM0_CC1	0: PA2 1: PA3 2: PA4 3: PA5			13: PB11 14: PB12 15: PB13	16: PB14 17: PB15		24: PC6 25: PC7 26: PC8 27: PC9	28: PC10 29: PC11 31: PD9	Wide timer 0 Capture Compare input / output channel 1.
WTIM0_CC2	0: PA4 1: PA5		11: PB11	12: PB12 13: PB13 14: PB14 15: PB15		22: PC6 23: PC7	24: PC8 25: PC9 26: PC10 27: PC11	29: PD9 30: PD10 31: PD11	Wide timer 0 Capture Compare input / output channel 2.
WTIM0_CDTI0		7: PB11	8: PB12 9: PB13 10: PB14 11: PB15		18: PC6 19: PC7	20: PC8 21: PC9 22: PC10 23: PC11	25: PD9 26: PD10 27: PD11	28: PD12 29: PD13 30: PD14 31: PD15	Wide timer 0 Complimentary Dead Time Insertion channel 0.
WTIM0_CDTI1		5: PB11 6: PB12 7: PB13	8: PB14 9: PB15		16: PC6 17: PC7 18: PC8 19: PC9	20: PC10 21: PC11 23: PD9	24: PD10 25: PD11 26: PD12 27: PD13	28: PD14 29: PD15 30: PF0 31: PF1	Wide timer 0 Complimentary Dead Time Insertion channel 1.
WTIM0_CDTI2	3: PB11	4: PB12 5: PB13 6: PB14 7: PB15		14: PC6 15: PC7	16: PC8 17: PC9 18: PC10 19: PC11	21: PD9 22: PD10 23: PD11	24: PD12 25: PD13 26: PD14 27: PD15	28: PF0 29: PF1 30: PF2 31: PF3	Wide timer 0 Complimentary Dead Time Insertion channel 2.

Certain alternate function locations may have non-interference priority. These locations will take precedence over any other functions selected on that pin (i.e. another alternate function enabled to the same pin inadvertently).

Some alternate functions may also have high speed priority on certain locations. These locations ensure the fastest possible paths to the pins for timing-critical signals.

The following table lists the alternate functions and locations with special priority.

Table 6.4. Alternate Functionality Priority

Alternate Functionality	Location	Priority
CMU_CLKI0	1: PF7	High Speed

6.4 Analog Port (APORT) Client Maps

The Analog Port (APORT) is an infrastructure used to connect chip pins with on-chip analog clients such as analog comparators, ADCs, DACs, etc. The APORT consists of a set of shared buses, switches, and control logic needed to configurably implement the signal routing. Figure 6.2 APORT Connection Diagram on page 104 shows the APORT routing for this device family (note that available features may vary by part number). A complete description of APORT functionality can be found in the Reference Manual.

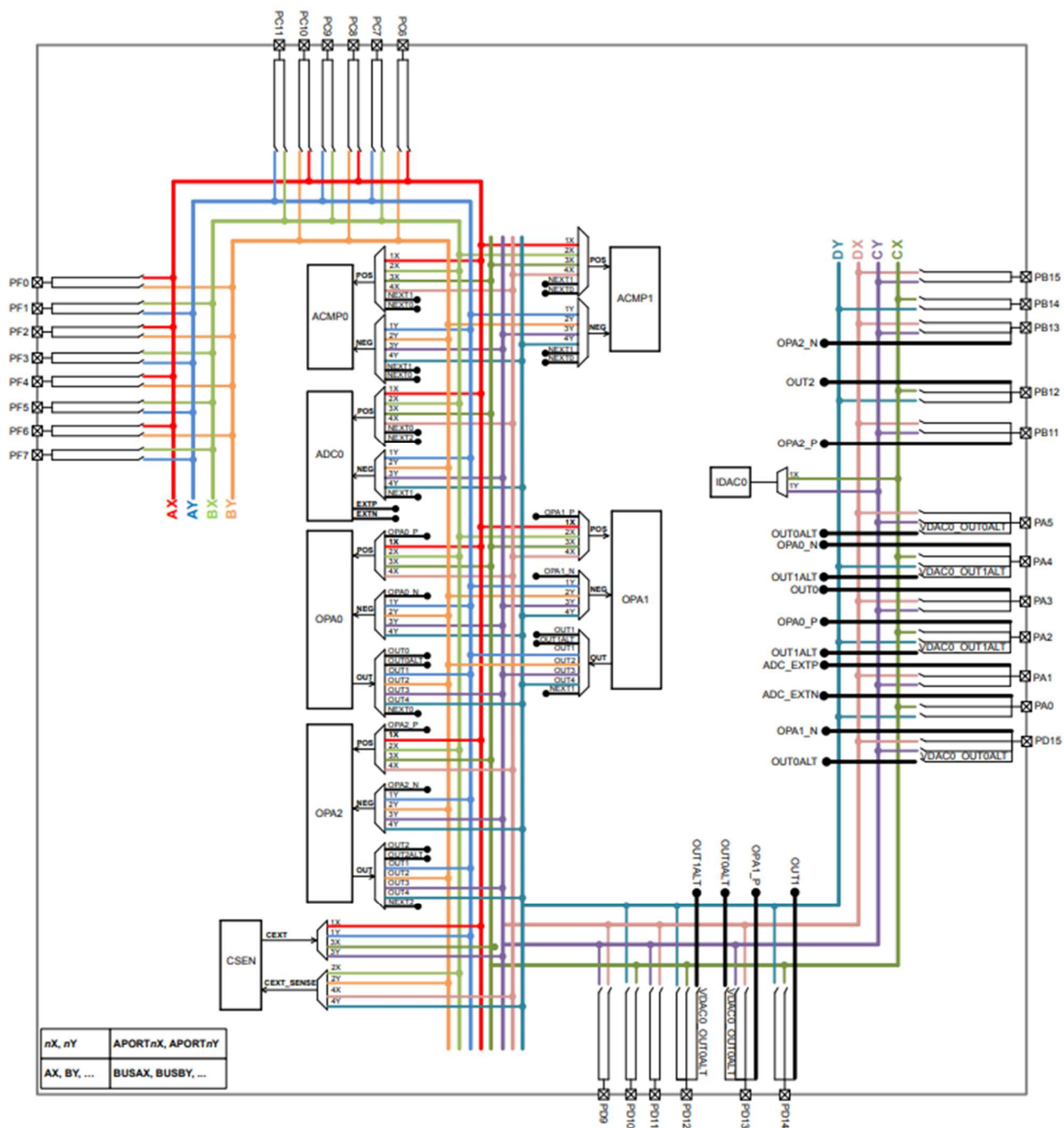

Figure 6.2. APORT Connection Diagram

Client maps for each analog circuit using the APORT are shown in the following tables. The maps are organized by bus, and show the peripheral's port connection, the shared bus, and the connection from specific bus channel numbers to GPIO pins.

In general, enumerations for the pin selection field in an analog peripheral's register can be determined by finding the desired pin connection in the table and then combining the value in the Port column (APORT__), and the channel identifier (CH__). For example, if pin PF7 is available on port APORT2X as CH23, the register field enumeration to connect to PF7 would be APORT2XCH23. The shared bus used by this connection is indicated in the Bus column.

Table 6.5. ACMP0 Bus and Pin Mapping

APORT4Y	APORT4X	APORT3Y	APORT3X	APORT2Y	APORT2X	APORT1Y	APORT1X	Port
BUSDY	BUSDX	BUSCY	BUSCX	BUSBY	BUSBX	BUSAY	BUSAX	Bus
PB14	PB15	PB15	PB14					CH31
								CH30
PB12	PB13	PB13	PB12					CH29
								CH28
								CH27
								CH26
								CH25
								CH24
					PF7	PF7		CH23
				PF6			PF6	CH22
					PF5	PF5		CH21
				PF4			PF4	CH20
					PF3	PF3		CH19
				PF2			PF2	CH18
					PF1	PF1		CH17
				PF0			PF0	CH16
								CH15
								CH14
	PA5	PA5						CH13
PA4			PA4					CH12
	PA3	PA3			PC11	PC11		CH11
PA2			PA2	PC10			PC10	CH10
	PA1	PA1			PC9	PC9		CH9
PA0			PA0	PC8			PC8	CH8
	PD15	PD15			PC7	PC7		CH7
PD14			PD14	PC6			PC6	CH6
	PD13	PD13						CH5
PD12			PD12					CH4
	PD11	PD11						CH3
PD10			PD10					CH2
	PD9	PD9						CH1
								CH0

Table 6.6. ACMP1 Bus and Pin Mapping

APORT4Y	APORT4X	APORT3Y	APORT3X	APORT2Y	APORT2X	APORT1Y	APORT1X	Port
BUSDY	BUSDX	BUSCY	BUSCX	BUSBY	BUSBX	BUSAY	BUSAX	Bus
	PB15	PB15						CH31
PB14			PB14					CH30
	PB13	PB13						CH29
PB12			PB12					CH28
	PB11	PB11						CH27
								CH26
								CH25
								CH24
					PF7	PF7		CH23
				PF6			PF6	CH22
					PF5	PF5		CH21
				PF4			PF4	CH20
					PF3	PF3		CH19
				PF2			PF2	CH18
					PF1	PF1		CH17
				PF0			PF0	CH16
								CH15
								CH14
	PA5	PA5						CH13
PA4								CH12
	PA3	PA3	PA4					CH11
PA2				PC10	PC11	PC11		CH10
	PA1	PA1	PA2				PC10	CH9
PA0			PA0	PC8	PC9	PC9	PC8	CH8
	PD15	PD15			PC7	PC7		CH7
PD14			PD14	PC6			PC6	CH6
	PD13	PD13						CH5
PD12			PD12					CH4
	PD11	PD11						CH3
PD10			PD10					CH2
	PD9	PD9						CH1
								CH0

Table 6.7. ADC0 Bus and Pin Mapping

APORT4Y	APORT4X	APORT3Y	APORT3X	APORT2Y	APORT2X	APORT1Y	APORT1X	Port
BUSDY	BUSDX	BUSCY	BUSCX	BUSBY	BUSBX	BUSAY	BUSAX	Bus
	PB15	PB15						CH31
PB14			PB14					CH30
	PB13	PB13						CH29
PB12			PB12					CH28
	PB11	PB11						CH27
								CH26
								CH25
								CH24
					PF7	PF7		CH23
				PF6			PF6	CH22
					PF5	PF5		CH21
				PF4			PF4	CH20
					PF3	PF3		CH19
				PF2			PF2	CH18
					PF1	PF1		CH17
				PF0			PF0	CH16
								CH15
								CH14
	PA5	PA5						CH13
PA4								CH12
	PA3	PA3	PA4					CH11
PA2				PC10	PC11	PC11		CH10
	PA1	PA1	PA2				PC10	CH9
PA0			PA0	PC8			PC8	CH8
	PD15	PD15						CH7
PD14			PD14	PC6			PC6	CH6
	PD13	PD13						CH5
PD12			PD12					CH4
	PD11	PD11						CH3
PD10			PD10					CH2
	PD9	PD9						CH1
								CH0

Table 6.10. VDAC0 / OPA Bus and Pin Mapping

Port	Bus	CH31	CH30	CH29	CH28	CH27	CH26	CH25	CH24	CH23	CH22	CH21	CH20	CH19	CH18	CH17	CH16	CH15	CH14	CH13	CH12	CH11	CH10	CH9	CH8	CH7	CH6	CH5	CH4	CH3	CH2	CH1	CH0	
OPA0_N																																		
APORT1Y	BUSAY									PF7		PF5		PF3		PF1					PC11			PC9		PC7								
APORT2Y	BUSBY										PF6		PF4		PF2		PF0						PC10		PC8		PC6							
APORT3Y	BUSCY	PB15		PB13		PB11												PA5		PA3		PA1		PD15		PD13		PD11		PD9				
APORT4Y	BUSDY		PB14		PB12															PA4		PA2		PA0		PD14		PD12		PD10				
OPA0_P																																		
APORT1X	BUSAX										PF6		PF4		PF2		PF0					PC10			PC8		PC6							
APORT2X	BUSBX									PF7		PF5		PF3		PF1						PC11		PC9		PC7		PC6						
APORT3X	BUSCX		PB14		PB12															PA4		PA2		PA0		PD14		PD12		PD10				
APORT4X	BUSDX	PB15		PB13		PB11														PA5		PA3		PA1		PD15		PD13		PD11		PD9		

Port	Bus	CH31	CH30	CH29	CH28	CH27	CH26	CH25	CH24	CH23	CH22	CH21	CH20	CH19	CH18	CH17	CH16	CH15	CH14	CH13	CH12	CH11	CH10	CH9	CH8	CH7	CH6	CH5	CH4	CH3	CH2	CH1	CH0
OPA2_OUT																																	
APORT1Y	BUSAY									PF7		PF5		PF3		PF1						PC11		PC9		PC7							
APORT2Y	BUSBY										PF6		PF4		PF2		PF0						PC10		PC8		PC6						
APORT3Y	BUSCY	PB15		PB13		PB11														PA5		PA3		PA1		PD15		PD13		PD11		PD9	
APORT4Y	BUSDY		PB14		PB12															PA4		PA2		PA0		PD14		PD12		PD10			
OPA2_P																																	
APORT1X	BUSAX										PF6		PF4		PF2		PF0						PC10		PC8		PC6						
APORT2X	BUSBX									PF7		PF5		PF3		PF1						PC11		PC9		PC7		PC6					
APORT3X	BUSCX		PB14		PB12															PA4		PA2		PA0		PD14		PD12		PD10			
APORT4X	BUSDX	PB15		PB13		PB11														PA5		PA3		PA1		PD15		PD13		PD11		PD9	
VDAC0_OUT0 / OPA0_OUT																																	
APORT1Y	BUSAY									PF7		PF5		PF3		PF1						PC11		PC9		PC7							
APORT2Y	BUSBY										PF6		PF4		PF2		PF0						PC10		PC8		PC6						
APORT3Y	BUSCY	PB15		PB13		PB11														PA5		PA3		PA1		PD15		PD13		PD11		PD9	
APORT4Y	BUSDY		PB14		PB12															PA4		PA2		PA0		PD14		PD12		PD10			

7. LGA64 Package Specifications

Refer to AN1223 for LGA Manufacturing Guidance.

7.1 LGA64 Package Dimensions

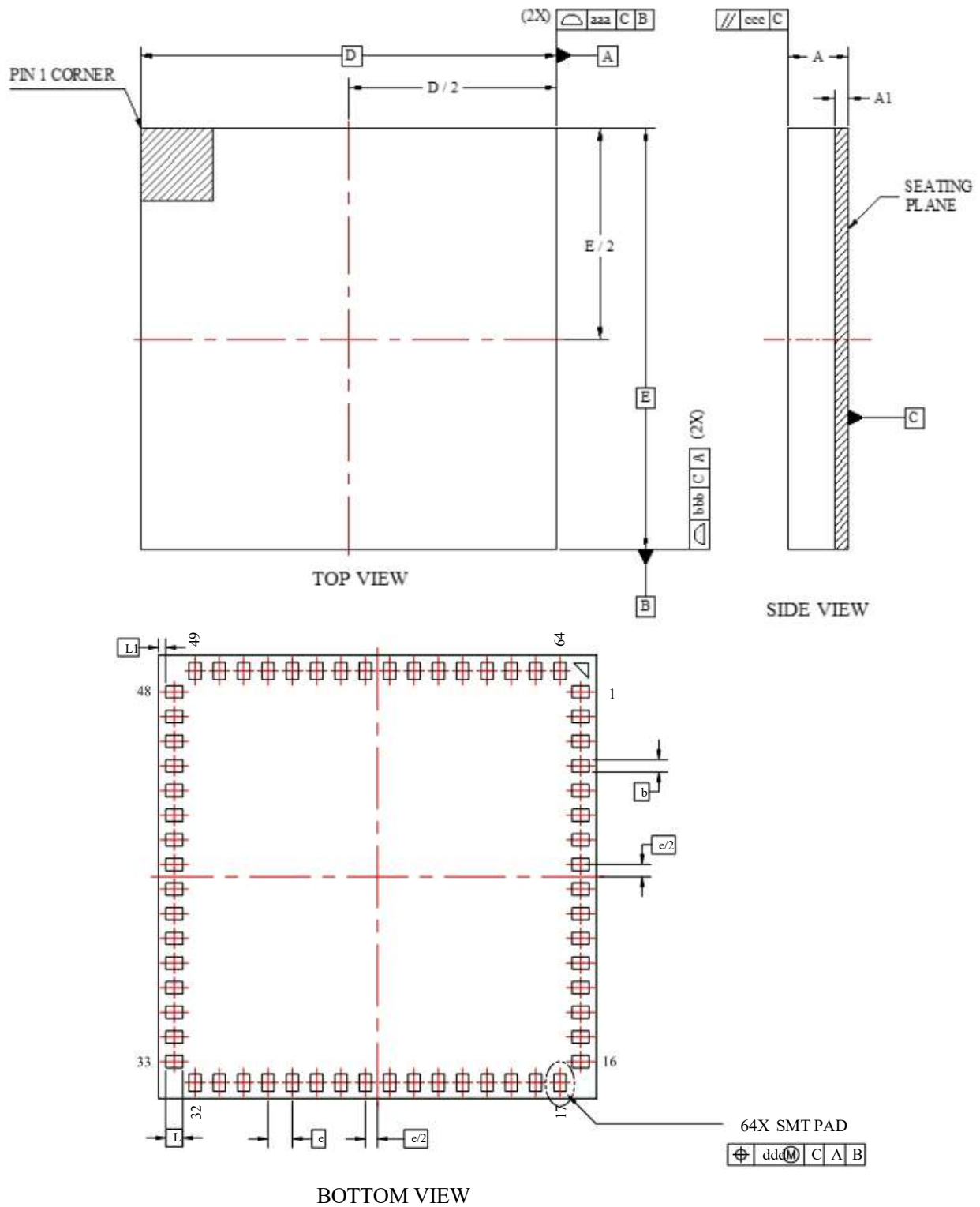

Figure 7.1. LGA64 Package Drawing

Table 7.1. LGA64 Package Dimensions

Dimension	Min	Typ	Max
A	1.12	1.21	1.30
A1	0.17	0.21	0.25
b	0.20	0.25	0.30
D	9.00 BSC		
e	0.50 BSC		
E	9.00 BSC		
L	0.30	0.35	0.40
L1	0.10	0.15	0.20
aaa	0.10		
bbb	0.10		
ccc	0.10		
ddd	0.10		

Note:

- 1.All dimensions shown are in millimeters (mm) unless otherwise noted.
- 2.Dimensioning and Tolerancing per ANSI Y14.5M-1994.
- 3.This drawing conforms to the JEDEC Solid State Outline MO-220.
- 4.Recommended card reflow profile is per the JEDEC/IPC J-STD-020 specification for Small Body Components.

7.2 LGA64 PCB Land Pattern

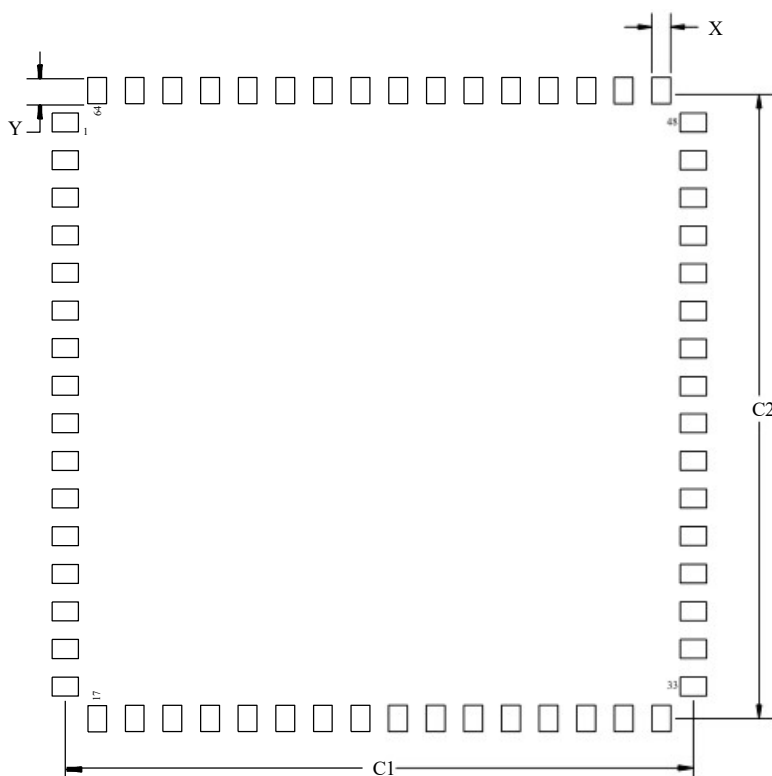

Figure 7.2. LGA64 PCB Land Pattern Drawing

Table 7.2. LGA64 PCB Land Pattern Dimensions

Dimension	Typ
C1	8.50
C2	8.50
X	0.30
Y	0.35

Note:

- 1.All dimensions shown are in millimeters (mm).
- 2.This Land Pattern Design is based on the IPC-7351 guidelines.
- 3.All dimensions shown are at Maximum Material Condition (MMC). Least Material Condition (LMC) is calculated based on a Fabrication Allowance of 0.05mm.
- 4.All metal pads are to be non-solder mask defined (NSMD). Clearance between the solder mask and the metal pad is to be 60µm minimum, all the way around the pad.
- 5.A stainless steel, laser-cut and electro-polished stencil with trapezoidal walls should be used to assure good solder paste release.
- 6.The stencil thickness should be 0.125mm (5 mils).
- 7.The ratio of stencil aperture to land pad size should be 1:1 for all pads.
- 8.A No-Clean, Type-3 solder paste is recommended.
- 9.The recommended card reflow profile is per the JEDEC/IPC J-STD-020 specification for Small Body Components.

Note: Above notes and stencil design are shared as recommendations only. A customer or user may find it necessary to use different parameters and fine tune their SMT process as required for their application and tooling.

7.3 LGA64 Package Marking



Figure 7.3. LGA64 Package Marking

The package marking consists of:

- P P P P P P P P P P – The part number designation.
- Y Y – The last 2 digits of the assembly year.
- W W – The 2-digit workweek when the device was assembled.
- T T T T T T – A trace or manufacturing code. The first letter is the device revision.
- C C – Country of Origin

8. Certifications

ZGM130S modules are not pre-certified and the end product containing this module should be certified for the respective regulatory body. Refer to AN1048 for detailed information related to Regulatory Certifications.

9. Revision History

Revision 1.3

June, 2022

- Added timing specifications for RESETn low time in [Table 4.19 General-Purpose I/O \(GPIO\) on page 36](#).
- Removed BIASPROG = 1, FULLBIAS = 0 specifications from [Table 4.22 Analog Comparator \(ACMP\) on page 41](#).
- Added debug information in [5.1 Typical ZGM130S Connections](#).
- Corrected the metal pad dimension in [Table 7.2 LGA64 PCB Land Pattern Dimensions on page 116](#)
- Added a note to [Table 7.2 LGA64 PCB Land Pattern Dimensions on page 116](#).
- Removed all references to RFSENSE.
- Removed all references to BOOT_TX and BOOT_RX.

Revision 1.2

December 2020

- Updated maximum TX power to 14 dBm.
- In [4.1.4.2 Current Consumption Using Radio 3.3 V with DC-DC](#) updated current consumptions for 912 MHz O-QPSK
- In [4.1.8.1 Sub-GHz RF Transmitter characteristics for 915 MHz Band](#)
 - Corrected FCC reference for non-restricted bands in :
 - SPURHARM_FCC_14
 - SPUROOB_FCC_14
 - Corrected FCC reference for PSD
- Added [4.1.8.2 Sub-GHz RF Transmitter characteristics for 915 MHz Band, +14 dBm](#) and other 912 MHz radio specs
- In [4.1.8.3 Sub-GHz RF Receiver Characteristics for 915 MHz Band](#), added sensitivity, image rejection, and blocking sensitivity for 912 MHz OQPSK PHY.
- Added reference to AN1223 in [7. LGA64 Package Specifications](#) section.
- In [7.3 LGA64 Package Marking](#) added package marking figure.
- Added [8. Certifications](#) section.

Revision 1.1

October 2019

- In the front page block diagram, updated the lowest energy mode for LETIMER.
- Updated [3.6.4 Low Energy Timer \(LETIMER\)](#) lowest energy mode.
- In [2. Ordering Information](#), updated ordering part numbers.

Revision 1.0

May 2019

- Added bullet about optional SAW filter to front page and feature lists.
- [Table 4.12 Sub-GHz RF Transmitter characteristics for 868 MHz Band on page 30](#) : Updated POUT_{MAX} footnote with details about SAW insertion loss.
- [Table 4.9 Sub-GHz RF Transmitter characteristics for 915 MHz Band on page 25](#) : Updated POUT_{MAX} footnote with details about SAW insertion loss.

Revision 0.5

January 2019

- Updated electrical characteristics with latest characterization results.

Revision 0.2

December 2018

- Crystal frequency changed to 39 MHz.
- Updated electrical characteristics with latest characterization estimates.
- [Table 4.9 Sub-GHz RF Transmitter characteristics for 915 MHz Band on page 25](#): PSD conditions updated to specify PSD at each data rate.
- [Table 6.3 Alternate Functionality Overview on page 92](#): Table formatting update.

Revision 0.1

August 2018

- Initial Release.

Disclaimer

Silicon Labs intends to provide customers with the latest, accurate, and in-depth documentation of all peripherals and modules available for system and software implementers using or intending to use the Silicon Labs products. Characterization data, available modules and peripherals, memory sizes and memory addresses refer to each specific device, and “Typical” parameters provided can and do vary in different applications. Application examples described herein are for illustrative purposes only. Silicon Labs reserves the right to make changes without further notice to the product information, specifications, and descriptions herein, and does not give warranties as to the accuracy or completeness of the included information. Without prior notification, Silicon Labs may update product firmware during the manufacturing process for security or reliability reasons. Such changes will not alter the specifications or the performance of the product. Silicon Labs shall have no liability for the consequences of use of the information supplied in this document. This document does not imply or expressly grant any license to design or fabricate any integrated circuits. The products are not designed or authorized to be used within any FDA Class III devices, applications for which FDA premarket approval is required or Life Support Systems without the specific written consent of Silicon Labs. A “Life Support System” is any product or system intended to support or sustain life and/or health, which, if it fails, can be reasonably expected to result in significant personal injury or death. Silicon Labs products are not designed or authorized for military applications. Silicon Labs products shall under no circumstances be used in weapons of mass destruction including (but not limited to) nuclear, biological or chemical weapons, or missiles capable of delivering such weapons. Silicon Labs disclaims all express and implied warranties and shall not be responsible or liable for any injuries or damages related to use of a Silicon Labs product in such unauthorized applications.

Trademark Information

Silicon Laboratories Inc.®, Silicon Laboratories®, Silicon Labs®, SiLabs® and the Silicon Labs logo®, Bluegiga®, Bluegiga Logo®, EFM®, EFM32®, EFR, Ember®, Energy Micro, Energy Micro logo and combinations thereof, “the world’s most energy friendly microcontrollers”, Redpine Signals®, WiSeConnect®, n-Link, ThreadArch®, EZLink®, EZRadio®, EZRadioPRO®, Gecko®, Gecko OS, Gecko OS Studio, Precision32®, Simplicity Studio®, Telegesis, the Telegesis Logo®, USBXpress®, Zentri, the Zentri logo and Zentri DMS, Z-Wave®, and others are trademarks or registered trademarks of Silicon Labs. ARM, CORTEX, Cortex-M3 and THUMB are trademarks or registered trademarks of ARM Holdings. Keil is a registered trademark of ARM Limited. Wi-Fi is a registered trademark of the Wi-Fi Alliance. All other products or brand names mentioned herein are trademarks of their respective holders.

